

Remote Access for Mitsubishi FX- and Q-Series PLCs

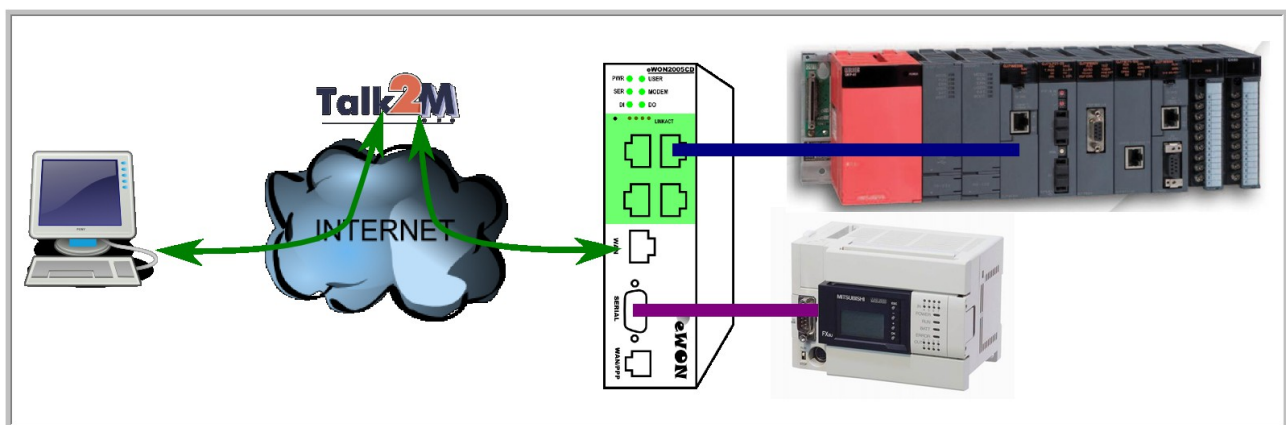

Contents

This guide explains in a few steps how to configure your eWON, your Talk2M account and your PLC software to access your Mitsubishi FX- and Q-Series PLCs for remote diagnosis and programming.

1. Hard- and software requirements.....	4
1.1 Hardware requirements.....	4
1.2 Software requirements.....	4
1.2.1 eWON related software.....	4
1.2.2 Mitsubishi MelSoft software.....	4
1.3 eWON Firmware Version.....	4
2. Objective.....	5
3. Typical configuration setup.....	6
4. Prerequisite: Determining suitable IP addresses.....	7
4.1 Internet connection using the WAN Interface.....	7
4.2 Internet connection by modem (GSM, PSTN, ADSL).....	8
4.3 For proper routing, remember.....	8
5. Reaching your eWON through the Internet.....	9
5.1 Step 1: Setting IP address of eWON LAN.....	9
5.2 Step 2: Configure eWON for Internet connection.....	12
5.3 Step 3: Creating the eWON in your Talk2M account.....	15
5.4 Step 4: Getting the Talk2M activation key for the eWON.....	18
5.5 Step 5: Configuring your eWON to connect to Talk2M.....	20
5.6 Step 6: Connecting the eWON remotely.....	23
5.7 Step 7: Terminating the remote connection.....	25
6. Linking eWON and PLC.....	26
6.1 Local link capabilities.....	26
6.2 Serial link configuration.....	27
6.2.1 Serial connection to FX-Series.....	28
6.2.2 Serial connection to Q-Series.....	29
6.3 Ethernet link configuration.....	30
7. PLC software mapping configuration.....	31
7.1 Serial connection.....	31
7.1.1 Creating a virtual serial port on your PC.....	31
7.1.2 Mitsubishi MelSoft GX configuration.....	34
7.2 Ethernet connection.....	37
7.2.1 Mitsubishi MelSoft GX configuration.....	37
8. PLC remote access	39
9. Troubleshooting.....	40
9.1 Cannot reach serial PLC?.....	40
9.2 Cannot reach Ethernet PLC?.....	40
10. Appendix 1 – Specifics for Modem connections.....	42
10.1 General.....	42
10.2 Configuring the eWON for Internet connection (Step 2).....	42
10.3 Creating the eWON in your Talk2M account (Step 3).....	44
10.4 Connecting the eWON remotely (Step 6).....	44
10.5 Terminating the remote connection (Step 7).....	45
11. Appendix 3 – Security aspects.....	46
11.1 Login security.....	46

Table of Contents

11.2 Traffic security.....	46
12. Appendix 4 – Serial cable information.....	47
12.1 FX-Series - RS422.....	47
12.2 Q-Series - RS232.....	48
Revision history.....	49

1. Hard- and software requirements

1.1 Hardware requirements

In order to follow this guide you'll need:

- 1 eWON with VPN capabilities (for example eWON 2101CD with integrated modem or a 2005CD with second Ethernet interface)
- 1 Mitsubishi PLC (FXx or Q Series)
- PC suitable to configure the eWON and the PLC
- Serial cable as per appendix 4 (for serial link only)

1.2 Software requirements

1.2.1 eWON related software

- ◆ **Web browser** – Internet Explorerⁱ or Firefoxⁱⁱ to configure the embedded eWON parameters.
- ◆ **eBuddy** – eWON detection and firmware maintenance utility
<http://support.ewon.biz/software.htm>
- ◆ **eCatcher** – VPN tunneling utility
<http://support.ewon.biz/software.htm>
Note: this utility will be used to create the Talk2M account and to connect to your eWON remotely.
- ◆ **eVCOM** – Virtual com port driver (for serial link only)
<http://support.ewon.biz/software.htm>

1.2.2 Mitsubishi MeSoft software

One of the following Mitsubishi Electric MeSoft software is required:

- ◆ **GX IEC Developer** – most powerful version supporting the entire PLC range
- ◆ **GX IEC Developer FX** - cut-down version of GX IEC Developer, supporting the FX-Series only.
- ◆ **GX Developer** – basic version supporting the entire PLC range
- ◆ **GX develop FX** - cut-down version of GX Developer, supporting the FX-Series only.

1.3 eWON Firmware Version

Successfully following these guidelines requires an eWON firmware version 6.1 s2 or higher. The eBuddy application allows you to upgrade your eWON firmware if required.

2. Objective

The objective of this document is to guide you through the steps required to enable remote access of your Mitsubishi PLCs.

The remote access setup is composed of 4 different parts:

- ◆ Communicating with your eWON through the Internet
- ◆ Connecting your eWON with your Mitsubishi PLC
- ◆ Configuring your Mitsubishi software to correctly communicate through the eWON.
- ◆ Accessing your PLC through the Internet
To configure the eWON, all you need is a Web Browser and to open the internal Web page of the eWON. (<http://10.0.0.53> is the default IP factory setting)
If you are connecting to an eWON for the first time, you should read the "Quick Start Guide for eWON" shipped with your eWON. This document explains step by step how to change the IP address of the eWON LAN port in order to be able to connect to it.

3. Typical configuration setup

Configuring remote access is simple. However, you will need to pay attention to the different IP ranges involved. The diagram below summarizes the different network ranges in use (IP numbers are examples).

When it is hooked on the Company LAN (or to the Site LAN) the configuration PC needs to be configured in DHCP-enabled mode for you to be able to go through the steps involving the general Ethernet/Internet infrastructure.

When it is hooked to the LAN-port of the eWON and the configuration PC needs to be configured with a fixed IP address - in the eWON LAN range - for you to be able to go through the steps involving the eWON (and the Ethernet connected PLCs).

Note 1: *Because iterations between IP ranges are necessary during the configuration process, you could consider using 2 different configuration PCs. It is no problem if you use only one single PC, the present guide mentions each change in IP configuration that will be required.*

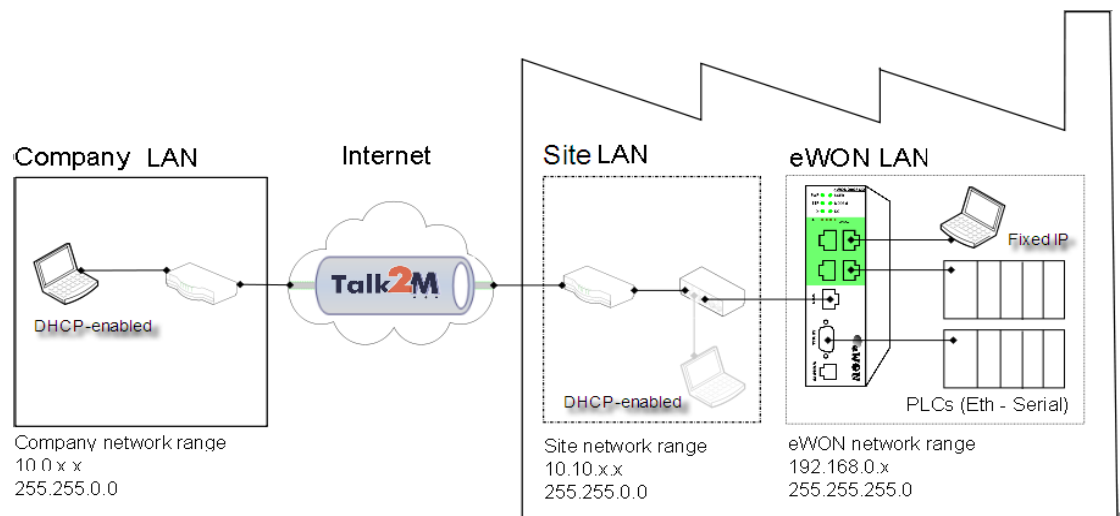

Note 2: *As the picture above shows, under normal circumstances the PC you will use to remotely access your eWON and PLCs will be on a different network than the site network. However, during configuration and testing, connecting PC to the site LAN is fine. As long as the site LAN address range is different than the eWON LAN address range you will not have routing issues.*

4. Prerequisite: Determining suitable IP addresses

To avoid routing problems later, it is better to start to configure the eWON and the PLC with LAN IP addresses that will be suitable.

The type of physical carrier (GPRS or WAN/LAN) your eWON will use to connect to the Internet will have an impact on your IP address selection.

Before starting the actual configuration, please read the general principles below.

4.1 Internet connection using the WAN Interface

If you plan to connect to the Internet using the WAN interface, the eWON will require a LAN IP address at the PLC side and a WAN IP address at the network side.

Example of IP ranges involved in a WAN/LAN configuration:

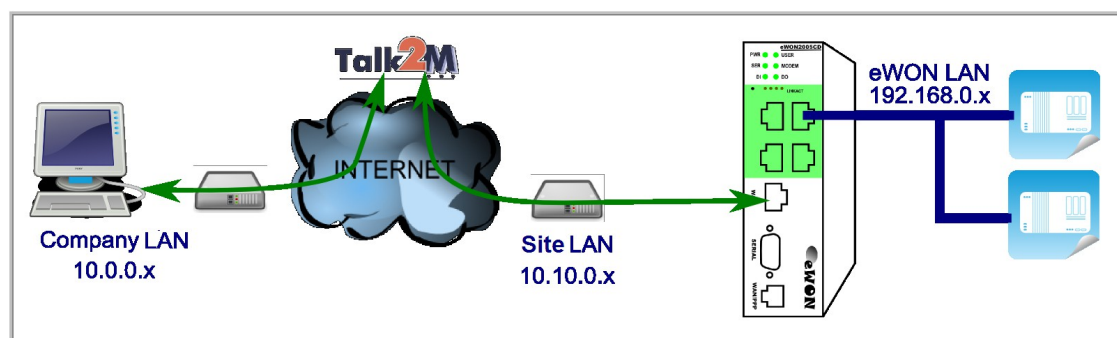

Important Note: The company network address ranges (Company LAN and Site LAN in the example above) are specified and managed by the respective network administrators. These ranges simply cannot be changed. So before configuring your eWON LAN IP address and your PLC IP addresses, please ask for:

1. The specified company LAN network range to be used by the PC that will initiate the remote connection (Company LAN).
In our example this range is 10.0.0.#
2. The specified company LAN network (Site LAN) range (and gateway) which the eWON WAN port will use to get Internet connection.
In our example this range is 10.10.0.#

Knowing the ranges in use at the Company and Site side, you will be able to select a range **outside** these networks for the eWON LAN-port and the PLC. In the above example, we could select addresses in the 192.168.0.# IP range for the eWON LAN and PLC since it does not overlap neither with the Company LAN range nor with the Site LAN range.

4.2 Internet connection by modem (GSM, PSTN, ADSL)

If you plan to connect to the Internet through a modem, you only need to select an IP address for the eWON LAN side. The IP address of the eWON LAN interface must be compatible with the IP address of the PLC, but be outside the network address space to which your PC is connected (Company LAN). If there is an overlap between the IP range of your PC and the IP-range of the eWON and the PLC LAN, the setup will not route correctly.

Example of IP ranges involved in a GPRS/Edge modem configuration:

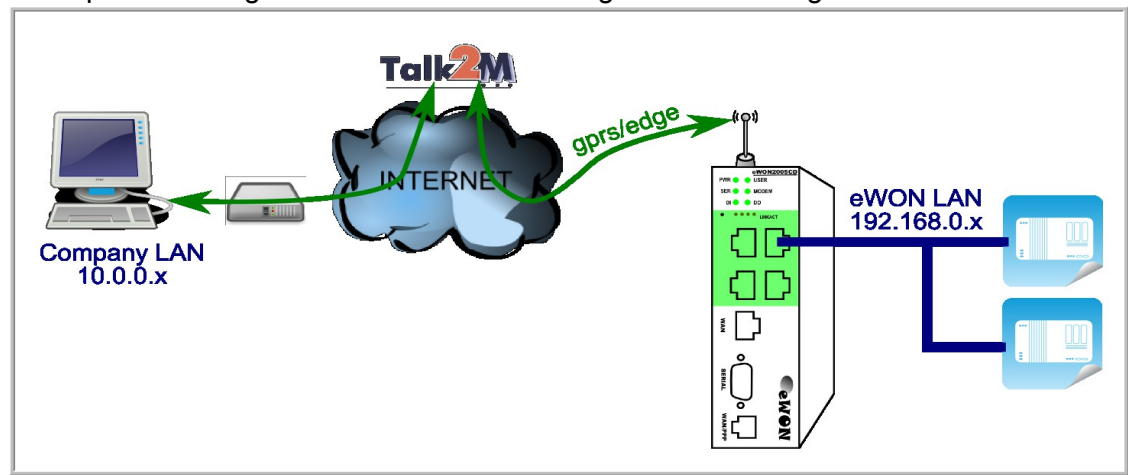

4.3 For proper routing, remember

1. The eWON LAN IP address must be part of the same IP range as the PLC LAN.
2. The eWON WAN and LAN IP addresses must be in different IP ranges. The WAN port of the eWON is generally DHCP-enabled, which is a good way to make sure that it will be compatible with the company network.
3. The remote PLC network (eWON LAN) must be in a different IP range than the company network on which your PC is connected (Company LAN).

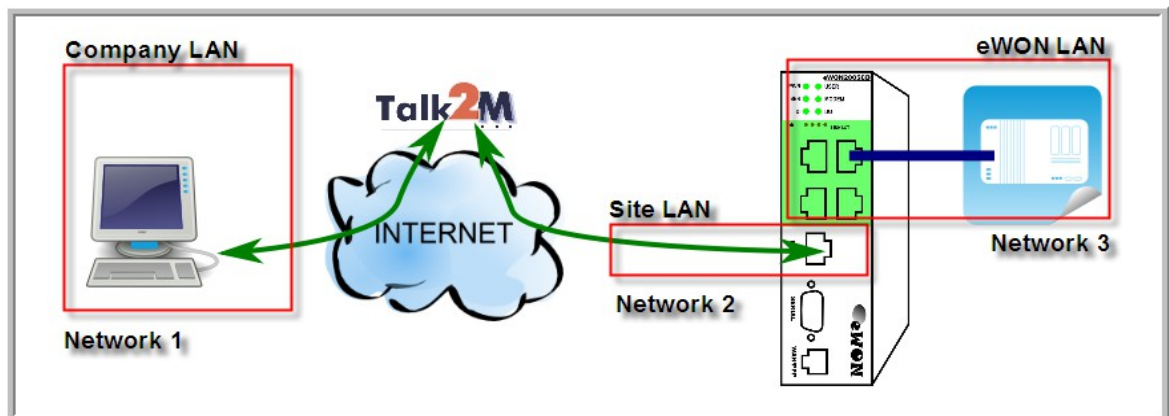

Network 3 = eWON LAN = PLC LAN (all in same range).
Network 3 ≠ Network 2
Network 3 ≠ Network 1

5. Reaching your eWON through the Internet

5.1 Step 1: Setting IP address of eWON LAN

Once you have selected your IP addresses, you can start configuring your eWON. In our example, we will change the default factory address 10.0.0.53 to 192.168.0.53.

To configure your eWON LAN IP:

1. This connection will usually be made through the Company network. It can also be made with a point-to-point link. At this stage there is no constraint on the IP range of your PC. For this step, eBuddy can access the eWON even if your PC and the eWON have different network address ranges. eBuddy – eWON *detection and firmware maintenance utility*
<http://support.ewon.biz/software.htm>

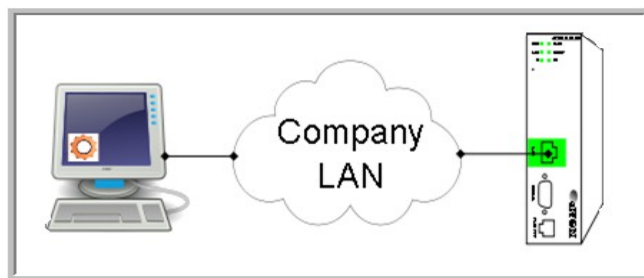

Connection through company LAN

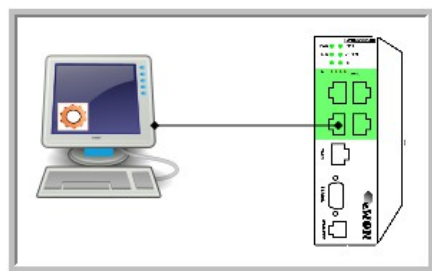

Point-to-point connection
(if eWON model has only 1 LAN port use **crossed** cable).

2. Start the **eBuddy** utility on your PC

5. Reaching your eWON through the Internet

3. In the home page, select **Set IP Address**

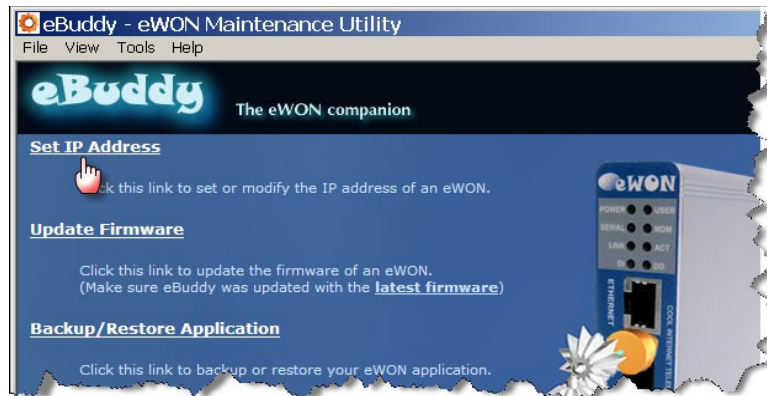

4. You don't need to fill out the Serial Number, just click on **Browse**

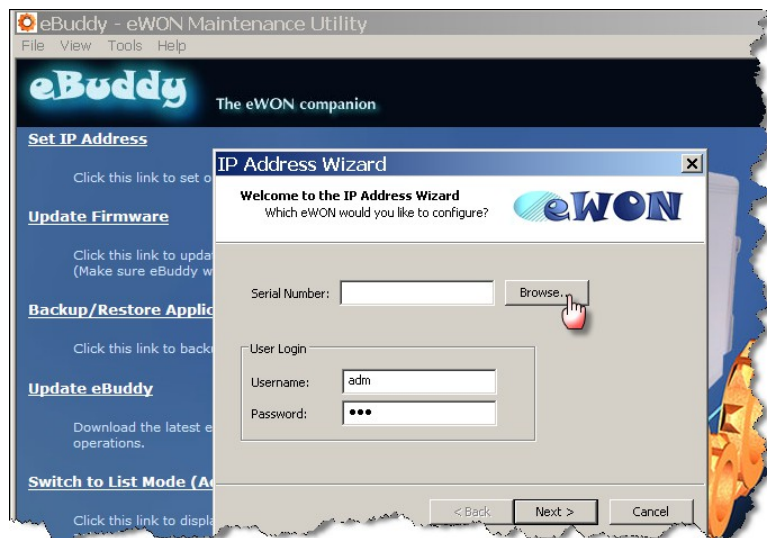

eBuddy finds your eWON. Select it by double-clicking on it and the IP Address window opens.

5. Enter new LAN IP address and Subnet Mask. Click **Next**

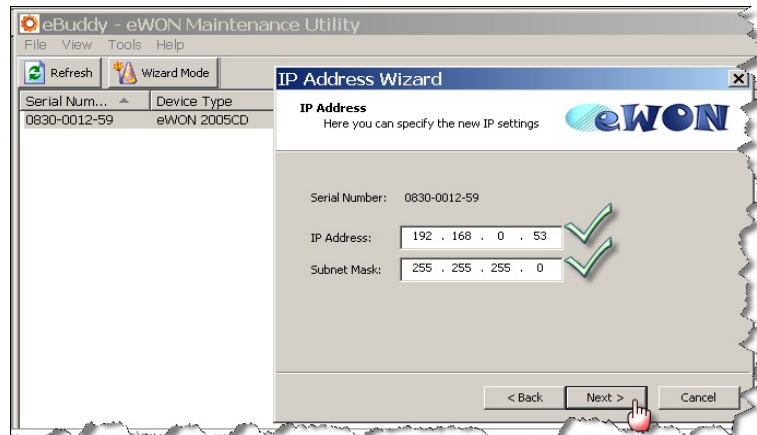

5. Reaching your eWON through the Internet

6. Wait until address update and device reboot are completed. Click **Finish**.

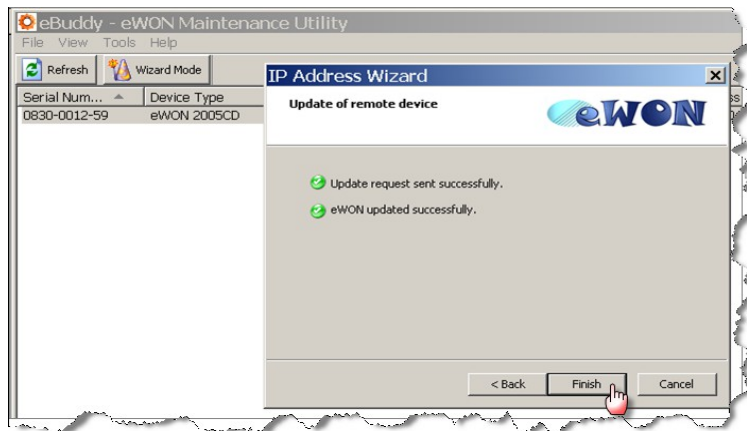

In our example the eWON was set to LAN IP address 192.168.0.53. As shown below, this address fits into the PLC-range and does not interfere with the Company LAN.

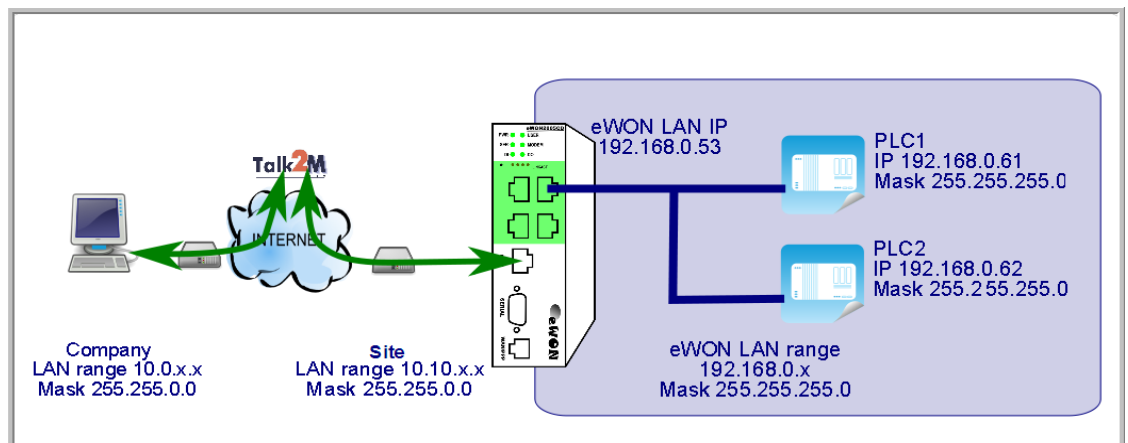

7. End of step 1

5.2 Step 2: Configure eWON for Internet connection

To configure your eWON's Internet connection :

1. Configure the network parameters of your configuration PC to encompass the IP range of the eWON LAN. To do this, go to START, Settings, Network Connections. Open the currently used connection, select the TCP/IP parameter row and select a fixed IP address within the range of the eWON LAN. Click OK to close the wizard.
2. Connect the PC to one of the LAN ports of the eWON.
3. Open your Internet browser and access the eWON internal Web page by typing the LAN address you just configured (in our example <http://192.168.0.53>)
4. To open the eWON wizard page, click on **Configuration** in the toolbar and then on the wizard  icon. The following page will be displayed:

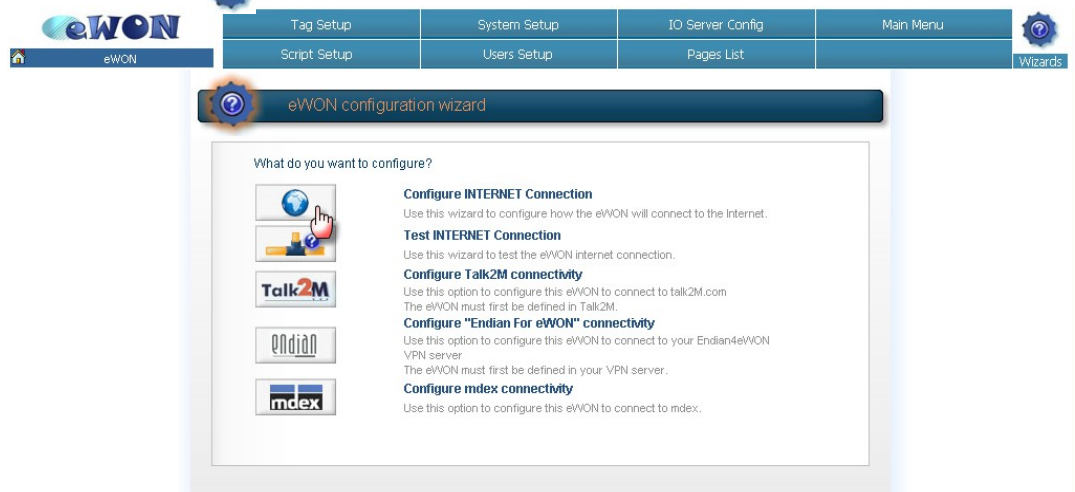

5. Click on the icon next to **Configure INTERNET Connection** to launch the wizard. Following window will be displayed (options in drop down are depending on hardware configuration) :



5. Reaching your eWON through the Internet

6. According to your eWON type (with a modem or a second Ethernet interface), you will have the possibility to choose between different connections:

- *Modem Connection*
- *Ethernet WAN* connection*
- *ADSL*

*WAN refers to **wide area network**, which is network that covers a broad external area using the Internet infrastructure, as opposed to LAN referring to **local area network** that is restricted to internal networks.

From the next step onwards, we will address the most current access which is **Ethernet WAN connection** (for modem connection refer to § 10 Appendix 1 – Specifics for Modem connections).

7. Make sure the WAN port of the eWON is physically connected with the company network. **Traffic LED do not lit yet as the connection is not yet defined.**
8. Select **Ethernet WAN connection**. The usual configuration for Ethernet is DHCP enabled (device obtains IP address and Internet access automatically from host). Use a fixed IP address, Gateway and DNS only if this is clearly required by the network admin.

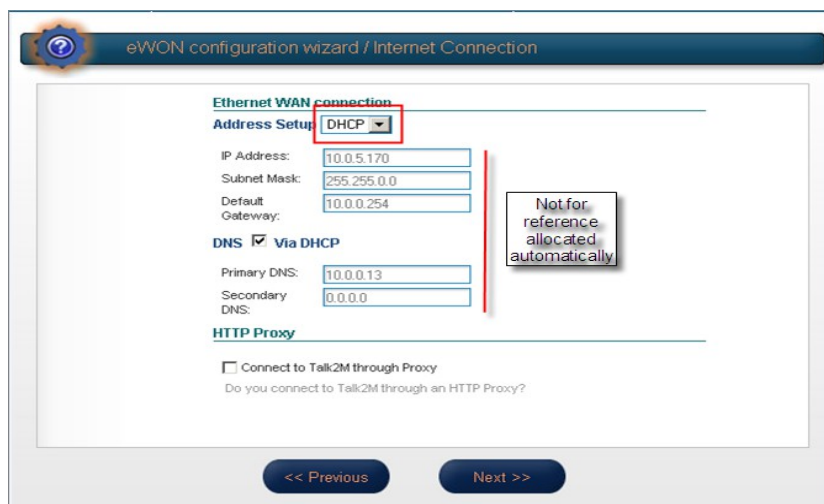

The screenshot shows the 'eWON configuration wizard / Internet Connection' window. The 'Ethernet WAN connection' section is active. Under 'Address Setup', the 'DHCP' option is selected in a dropdown menu. Below this, there are input fields for IP Address (10.0.5.170), Subnet Mask (255.255.0.0), and Default Gateway (10.0.0.254). The 'DNS' section has the 'Via DHCP' checkbox checked, with input fields for Primary DNS (10.0.0.13) and Secondary DNS (0.0.0.0). The 'HTTP Proxy' section has a checkbox for 'Connect to Talk2M through Proxy' which is unchecked. At the bottom, there are '<< Previous' and 'Next >>' buttons. A red box highlights the 'DHCP' dropdown, and a red vertical line is next to a text box that says 'Not for reference allocated automatically'.

9. Click **Next** and go to step 10 **Internet Connection Test**.
10. The last step of the Internet configuration consist in a communication test. This test should end up successfully as shown in the snapshot below:

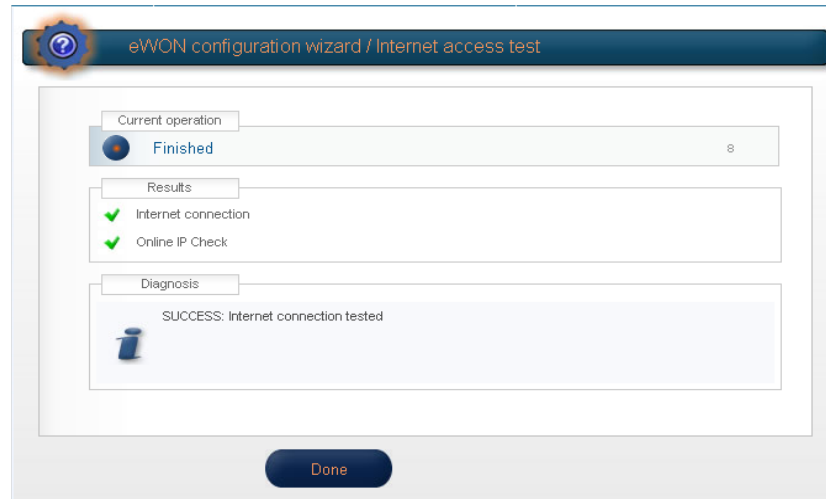

The Internet Connection means that the eWON is correctly configured for an Internet connection. If this test is not successful, then go back to the previous configuration steps and recheck all settings for compatibility and accuracy.

The **Online IP Check** means that the eWON was actually able to reach an IP address on Internet. **It might not be so critical if this particular test fails**. Go ahead with the procedure without being too much concerned.

You normally do not need to read it to complete the present procedure, but we mention for reference the detailed document describing the use of the wizard: AUG-019-0-EN-(eWON Configuration for Internet Access Using the Wizard). http://support.ewon.biz/docs/Talk2M_Free.htm

11. End of step 2.

5.3 Step 3: Creating the eWON in your Talk2M account

To connect to your eWON remotely, we will use eCatcher and Talk2M.

1. You can skip the present point if you already created a Talk2M account. If you haven't created your Talk2M account yet, install eCatcher and create your Talk2M account as per § 3 of the guide "Talk2M – Getting started on Service Free+" available at http://support.ewon.biz/docs/Talk2M_Free.htm. You can download eCatcher from this link as well.
2. Connect your configuration PC to the company LAN and configure its network parameters to DHCP enabled (acquiring an IP address automatically).
3. On the menu on the left side of the eCatcher interface click on the "+" (New eWON) icon in the eWON list section. The following window appears:

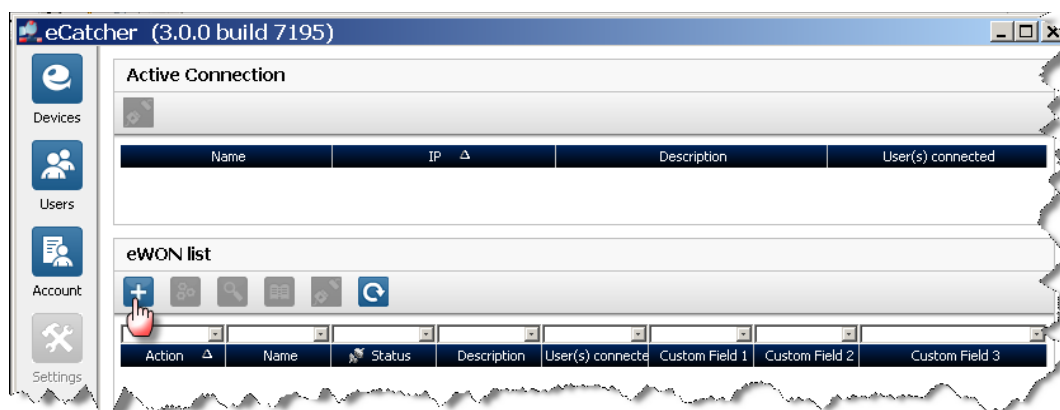

4. Enter the eWON name you want to use on the Talk2M server to identify the remote connection to your eWON.
5. The **eWON Serial Number** can be left empty. It will be encoded automatically during the Talk2M connection configuration of the eWON.

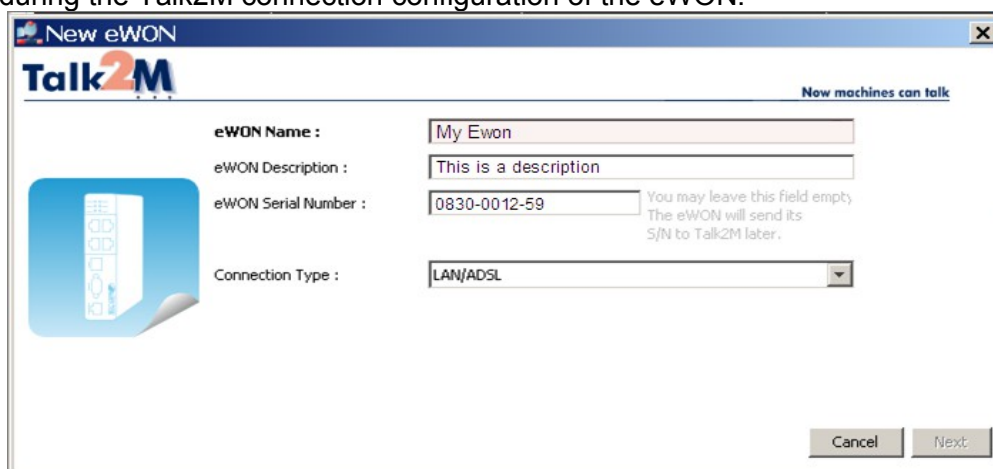

5. Reaching your eWON through the Internet

6. Select the **Connection Type** to specify how your eWON will be connected to the Talk2M server using:
 - ◆ a **LAN/ADSL** connection
 - ◆ a **GPRS/EDGE** connection or
 - ◆ an Internet connection over a **PSTN** connection (analog modem).

If you specify a GPRS/Edge connection, then you will be asked to specify the phone number. This will allow Talk2M to **wake up your eWON remotely** using a Wake-Up SMS as described in § 10 Appendix 1 – Specifics for Modem connections.

Click on **Next**.

Note: In older versions, you were asked to specify the **Remote Network** to reach behind the eWON like shown below. Since firmware version 6.2s0, when launching the eWON Talk2M wizard to enter the Talk2M-key, the wizard transfers the eWON LAN IP address to Talk2M automatically. In this case, this step is skipped.

New eWON

Talk2M Note: this step is skipped in newer Talk2M versions.... Now machines can talk

Remote Network Remote subnet accessible on the eWON LAN side (if any).

eWON LAN IP : e.g.: 10.0.0.53
Leave blank if you need not access the eWON's LAN.

Network Mask : e.g.: 255.255.255.0

... in this case, the Remote Network configuration is acquired automatically.

Previous Next

5. Reaching your eWON through the Internet

7. Click on **Next**.

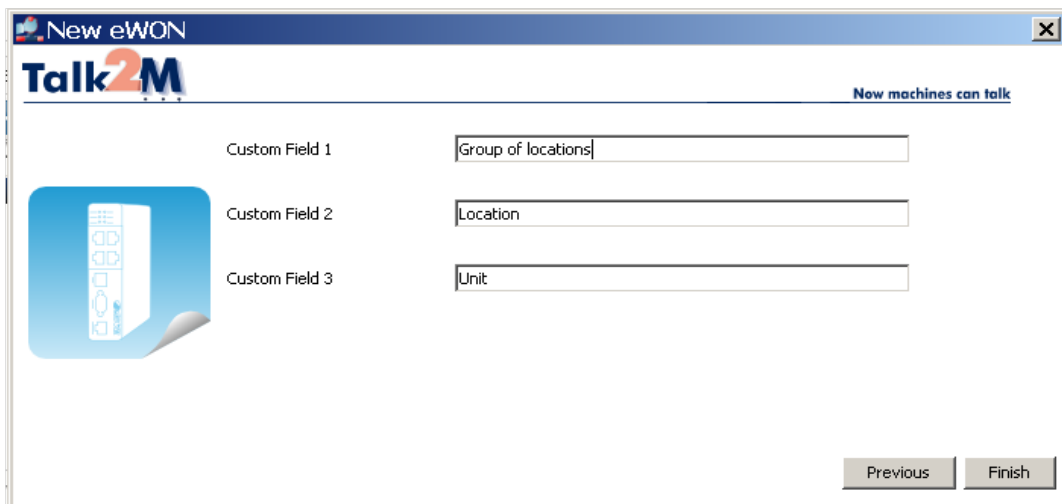

Here you can enter additional information concerning your remote connection. The **Custom Fields** can be used to classify or filter your different remote connections. This will allow you to find easily the eWON you need to connect to.

8. Click on **Finish** to add the eWON to the eWON list of your Talk2M account.

The new eWON account will now be displayed in the eWON List section on the lower part of the window.

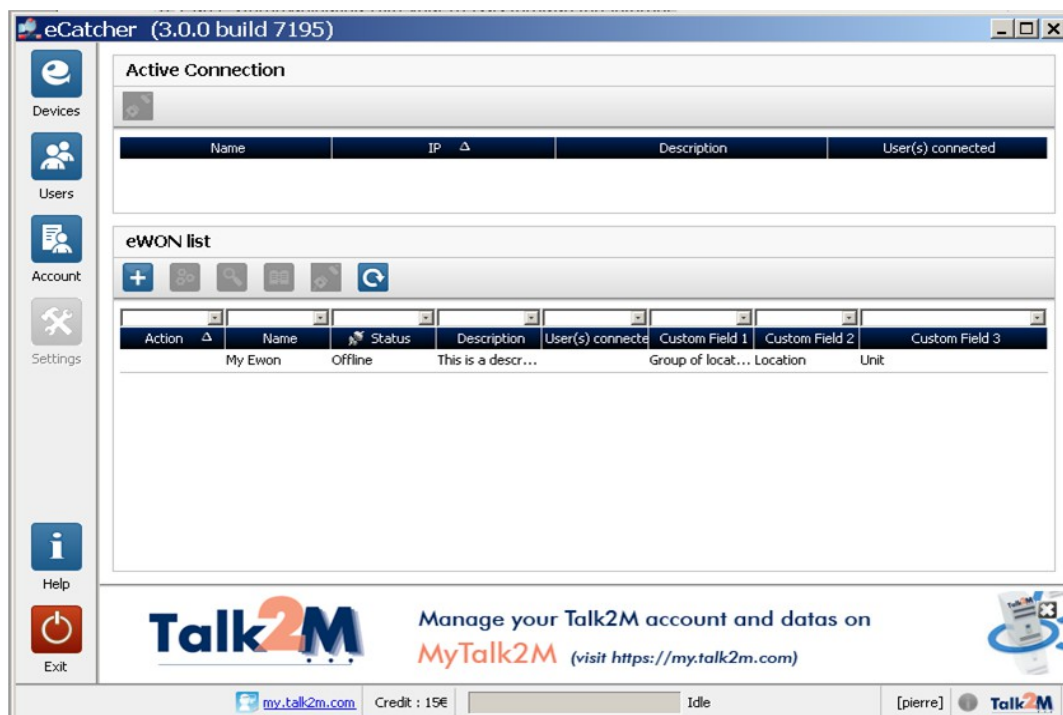

9. End of step 3.

5.4 Step 4: Getting the Talk2M activation key for the eWON

Up to now we only added the eWON on our Talk2M account, but we did not yet configure the eWON to connect to the Talk2M server.

To enable the eWON connecting to the Talk2M server, an activation key is needed. This key will allow the eWON to get back the VPN keys and certificates needed for the VPN connection. This step still uses the DHCP-enabled configuration of the previous step.

To get the activation key, proceed as follows:

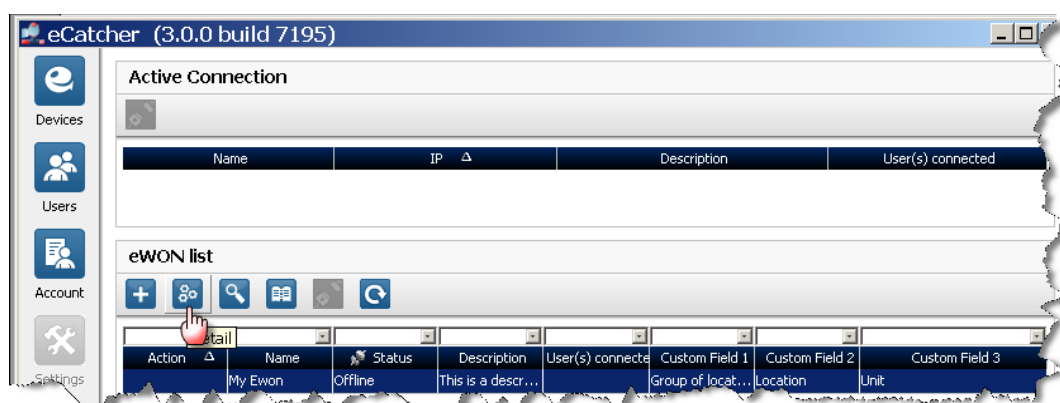

1. Select the eWON in the eWON list and click on the **Detail** button.

The eWON Detail window opens.

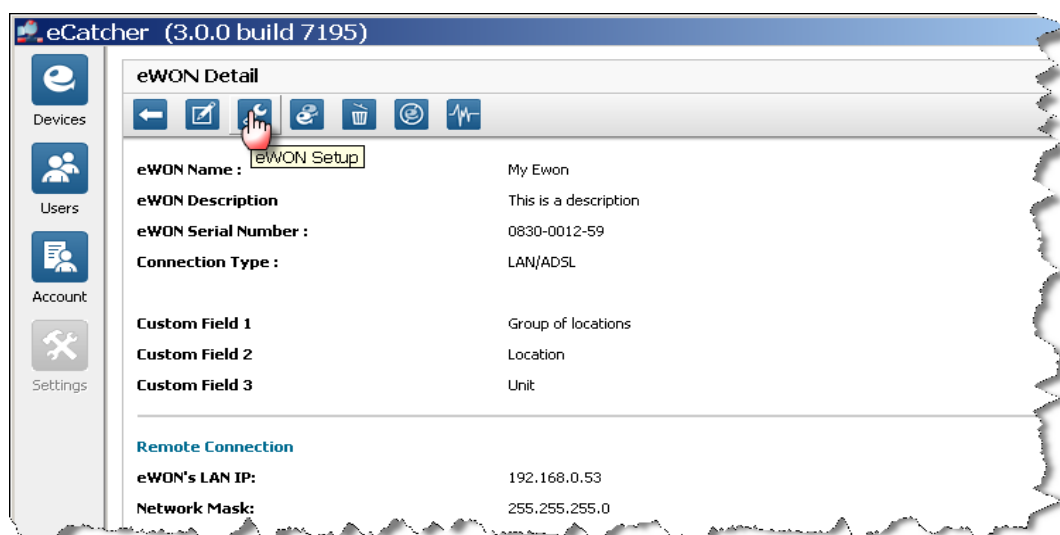

2. Click on the **eWON Setup** button.

5. Reaching your eWON through the Internet

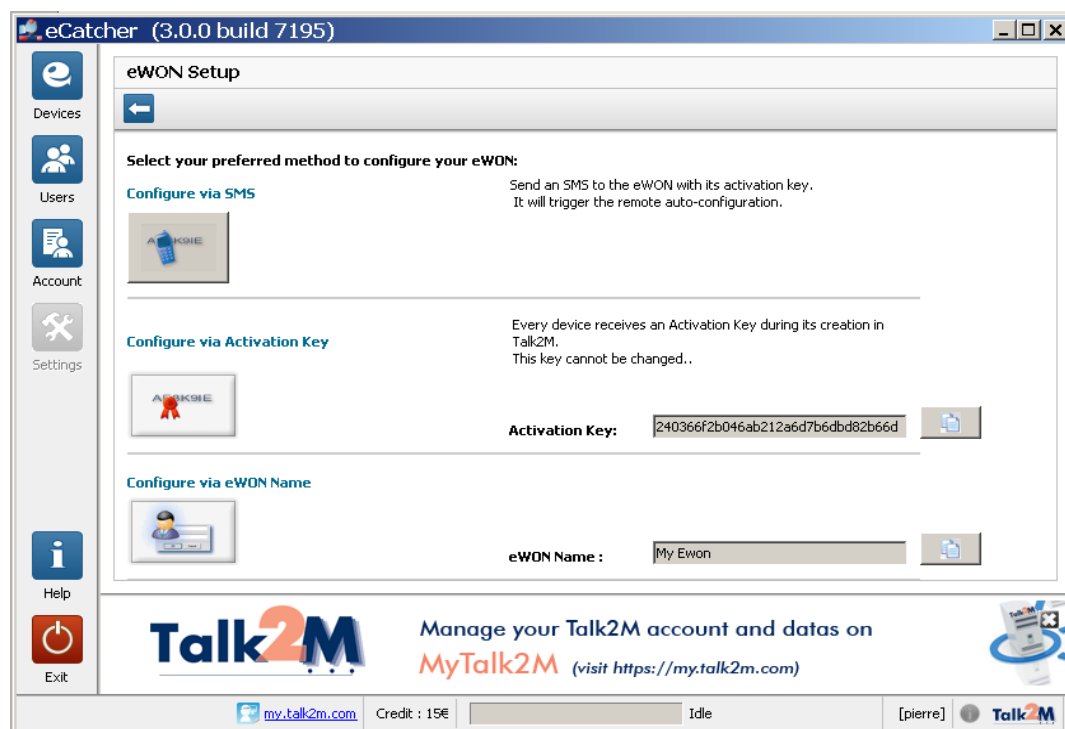

The following window opens:

3. Under the **Configure via Activation Key** section you will find the Activation Key needed for the eWON configuration. Click on the **Copy** icon to copy the activation key into the clipboard of your PC. Keep this information on your clipboard to

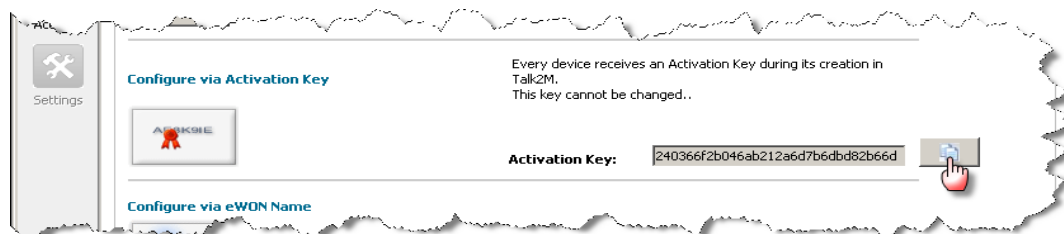

complete Step 5 (go to this step).

Note: Using the Activation Key is the standard procedure. Next to this method, there are 2 alternative methods:

- ◆ **Configure via eWON Name:** During the eWON Talk2M wizard, instead of using the Activation Key you can alternatively specify the **eWON Name** and use the user name and password of your Free+ account.
- ◆ **Configure via SMS:** If your eWON has a GSM modem and if the eWON is already configured for Internet connection, then you can also send an SMS to the eWON containing the activation key. When eWON receives the SMS, it will then trigger automatically the Talk2M connection wizard and will configure itself to connect to the Talk2M server.

4. End of step 4.

5.5 Step 5: Configuring your eWON to connect to Talk2M

1. Configure the network parameters of your configuration PC to encompass the IP range you used to allocate the LAN IP address to the eWON.
2. Connect the PC to one of the LAN ports of the eWON.
3. Open your Internet browser and access it's internal Web page by typing the LAN address you just configured (in our example http://192.168.0.53).
4. To open the eWON wizard page, click on **Configuration** in the toolbar and then on the **Wizard** icon.

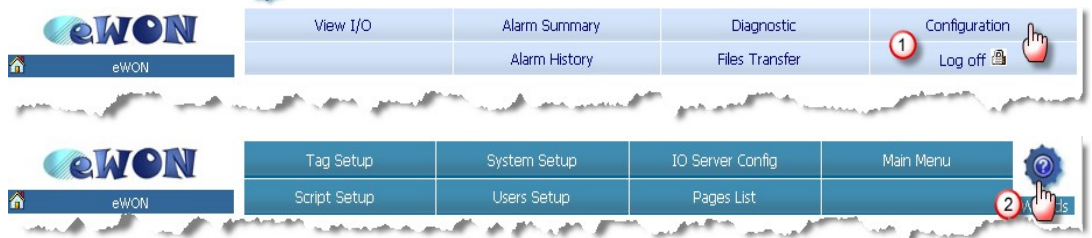

The wizard window will open:

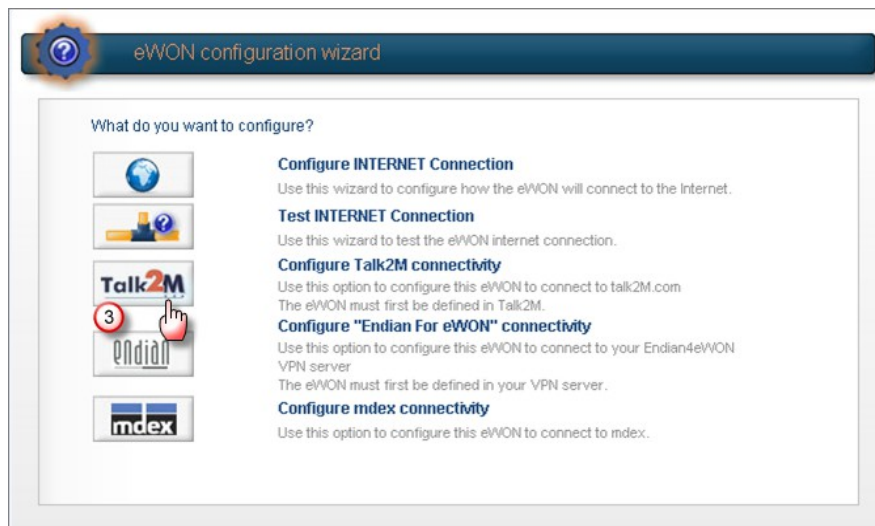

5. Click on the **Talk2M** wizard. The following window will be displayed:



5. Reaching your eWON through the Internet

6. Click on **Next** to register the eWON on the Talk2M server.
7. Click on **Register with ACTIVATION KEY**, as in the previous step, we copied the Activation Key to the clipboard of your PC. Paste the Activation Key (Ctrl+V).



The screenshot shows the 'eWON configuration wizard / Talk2M' window. It prompts the user to 'Select your preferred method for registering the eWON on Talk2M.com?'. Two options are presented: 'Register with eWON NAME' and 'Register with ACTIVATION KEY'. The 'Register with ACTIVATION KEY' option is selected, indicated by a red circle with the number '1' and a mouse cursor. Below this option, the 'Activation Key' field contains the value '240366f2b046ab212a6d7b6dbd82b66d', with a red circle and the number '2' around the key. At the bottom, the 'Next >>' button is highlighted with a red circle and the number '3'.

Important: Your eWON must have a working Internet Connection
Before using the wizard, the eWON Internet access must be correctly configured.

8. Click **Next**

Note: If you choose the **Registration with eWON NAME** method, then you will be asked to enter the Name you specified for the remote connection in your Talk2M account. You will also need to specify your Talk2M account name and enter the user name and the password which you use to connect to your Talk2M account.

The next window of the wizard will ask you if you need to connect through a Proxy server.

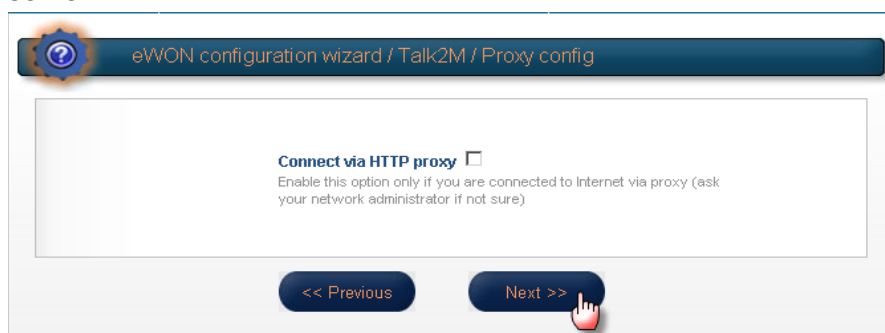

The screenshot shows the 'eWON configuration wizard / Talk2M / Proxy config' window. It contains a checkbox labeled 'Connect via HTTP proxy' which is currently unchecked. Below the checkbox, there is a note: 'Enable this option only if you are connected to Internet via proxy (ask your network administrator if not sure)'. At the bottom, the 'Next >>' button is highlighted with a red circle and a mouse cursor.

9. Check this option only if you need to specify a Proxy server for the Internet connection. Otherwise leave this option unchecked and click **Next**.

5. Reaching your eWON through the Internet

10. The Talk2M registration will now start and the result will be displayed on the wizard page:

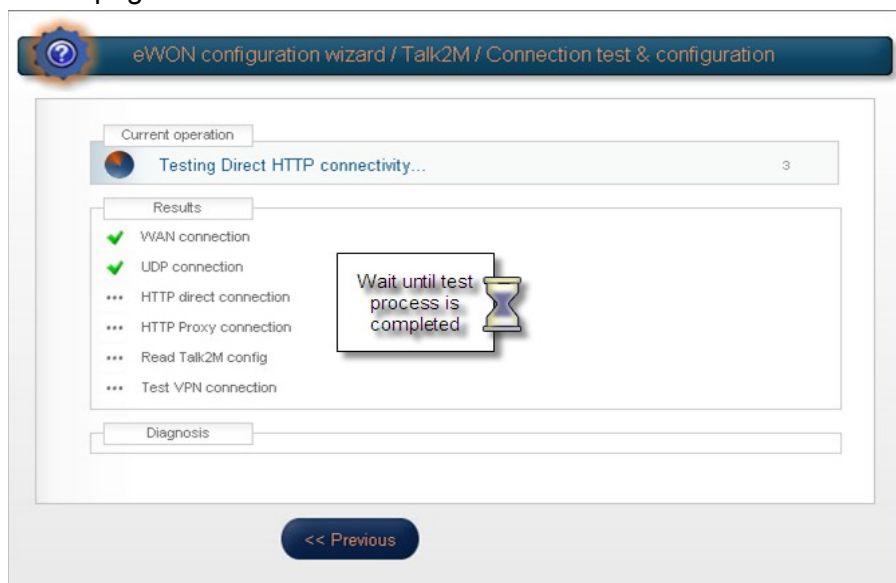

The eWON will first test the different connections needed to connect to the Talk2M server (UDP and HTTP or HTTP using a Proxy). Then the eWON will connect to the Talk2M server and retrieve the VPN keys. At the end, the eWON will establish the VPN connection to the Talk2M server.

Once the registration and configuration of the eWON are completed, the result will be displayed on the Wizard page as shown in the following picture:

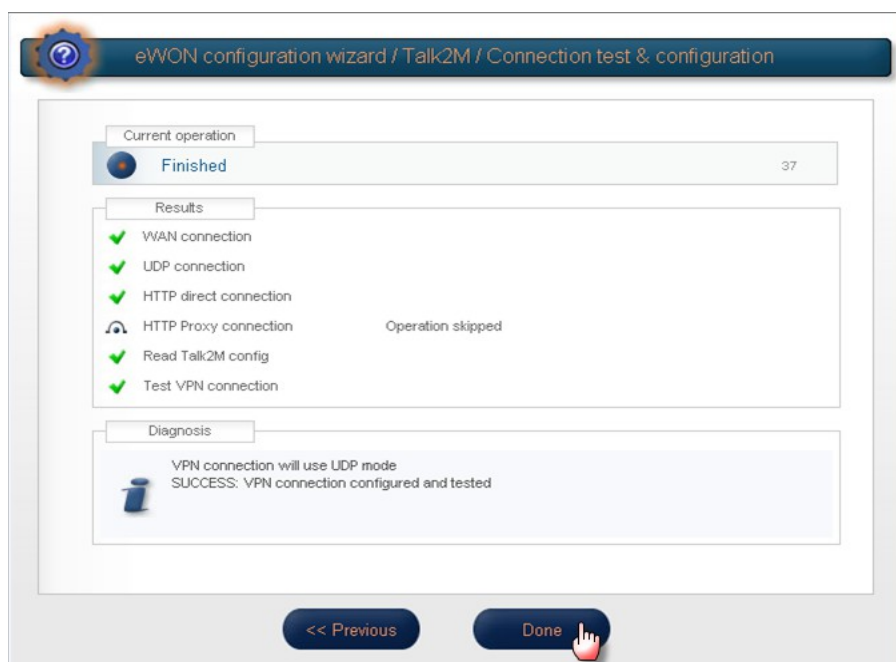

11. Click on the **Done** button to close the wizard.
Your eWON is now configured to connect to the Talk2M server.
12. End of step 5.

5.6 Step 6: Connecting the eWON remotely

Now that the eWON is configured to connect to Talk2M, we can establish the remote connection to the eWON.

1. Connect your configuration PC to the company LAN and configure its network parameters to DHCP enabled (acquiring an IP address automatically).
2. Launch eCatcher and open your Talk2M account.
3. In the eWON list section select the eWON you want to use for the remote connection.



The eWON which you just configured should now be displayed as on line (green tick in the action column). This means that the eWON has established its VPN connection to the Talk2M server.

4. Double-click the **online icon** or click on the **Connect** button displayed in the eWON list menu to establish the remote connection to this eWON. eCatcher will now establish the VPN connection to the Talk2M server.
5. Once the VPN connection to the eWON is established, the eWON will be displayed in the **Active connection** section on the top of the window.

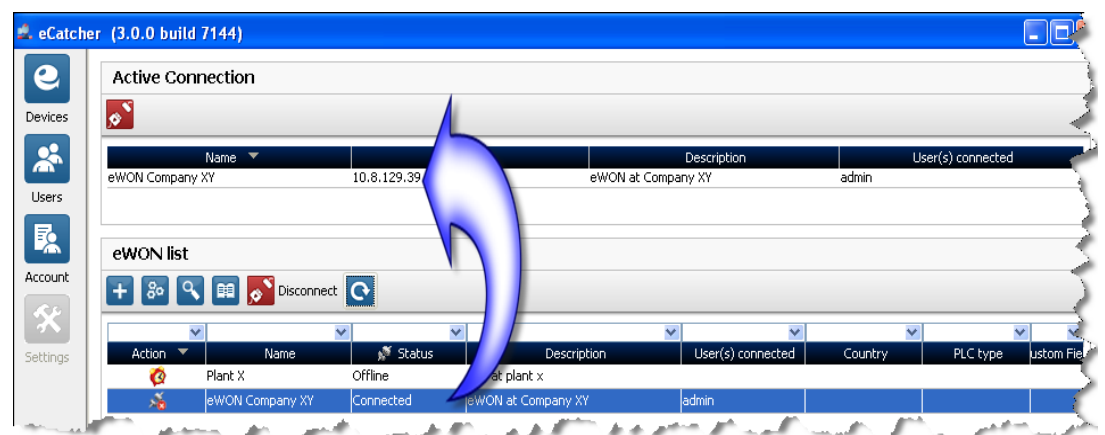

5. Reaching your eWON through the Internet

- The PC is now connected to the eWON using the VPN tunnel and you can start to use the remote connection.
- If you want/need to connect to the eWON itself, you can click on the IP address link in the **Active Connection** section, as displayed in the following picture. Once the home page of the eWON web interface is displayed, you know for sure that your connection is effective.

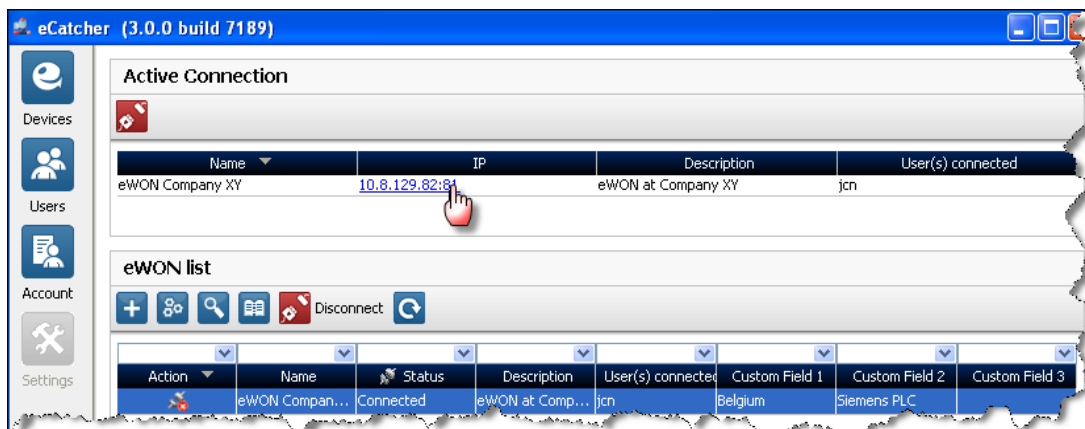

Note: For specifics related to modem connection (including GPRS/Edge) please go to § [10 Appendix 1 – Specifics for Modem connections](#) at the end of this guide.

- End of step 6.

5.7 Step 7: Terminating the remote connection

1. Click on the disconnect button in the Active connection section. This will close the VPN connection with the eWON.

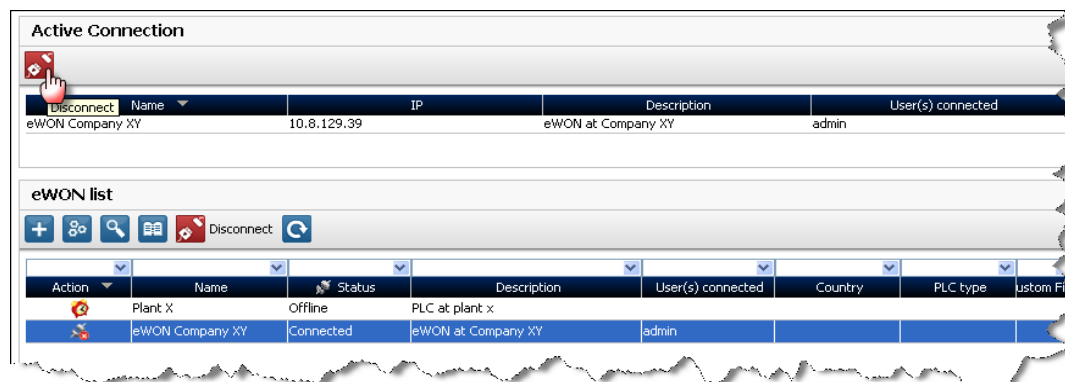

2. **Note:** For specifics related to modem connection (including GPRS/Edge) please go to § 10 [Appendix 1 – Specifics for Modem connections](#) at the end of this guide.
3. End of step number 7.

6. Linking eWON and PLC

6.1 Local link capabilities

Depending on whether the PLC will be connected to the eWON with a **serial** or **Ethernet** link, the eWON configuration and the connection to the PLC will be slightly different. Both types of connections will be explained.

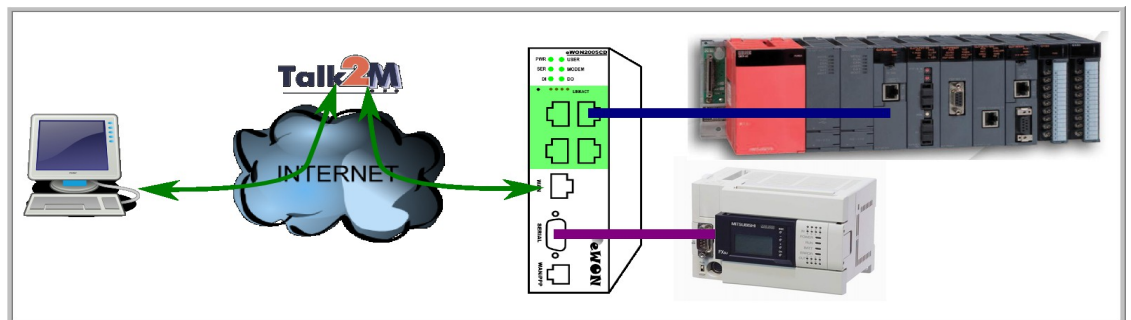

Keep in mind that you can combine both connection types without any problem. For example, you can connect at the same time to a FX-Series PLC using the serial port of the eWON and connect to one or more Q-Series PLC(s) using the Ethernet connection between the eWON and the PLC.

6.2 Serial link configuration

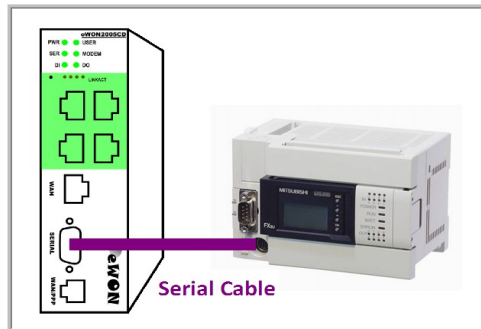

Note: Remote access to a serial connected Mitsubishi PLCs uses a VCOM solution (using a virtual port), not an IO Server. The MitsuFX IO server is only for polling purposes.

1. For **FX-series** PLCs, you have to set the serial port dip switch of the eWON to RS422/RS485 mode (1 ON all others OFF) to allow communication with the PLC.

For the **Q-Series** PLCs, you have to set the serial port dip switch of the eWON to RS232 mode (all OFF) to allow communication with the PLC.

Please see [Appendix 4 – Serial cable information](#) for serial cable specifications.

2. To configure the VCOM feature on the eWON, go to the eWON Web page either using the just configured VPN tunnel or a point-to-point connection to the eWON LAN port.

Follow the path **Configuration** → **System Setup** → **General** → **Net Services** → **VCOM** as shown below:

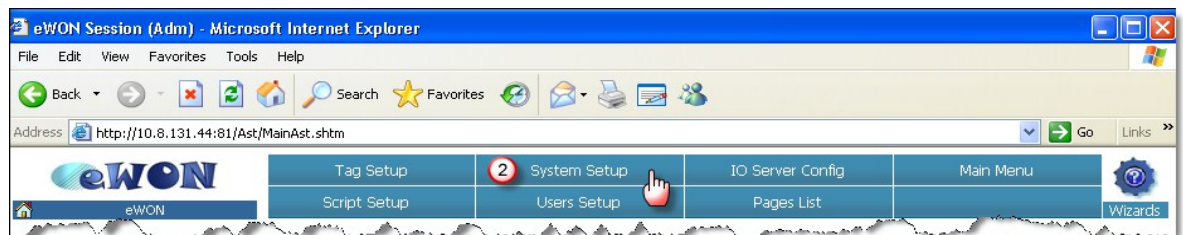
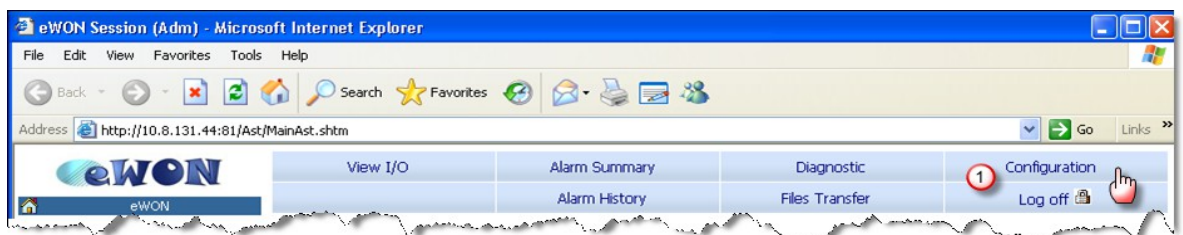

6.2.1 Serial connection to FX-Series

1. For the **FX-Series**, configure VCOM properties using the following properties:

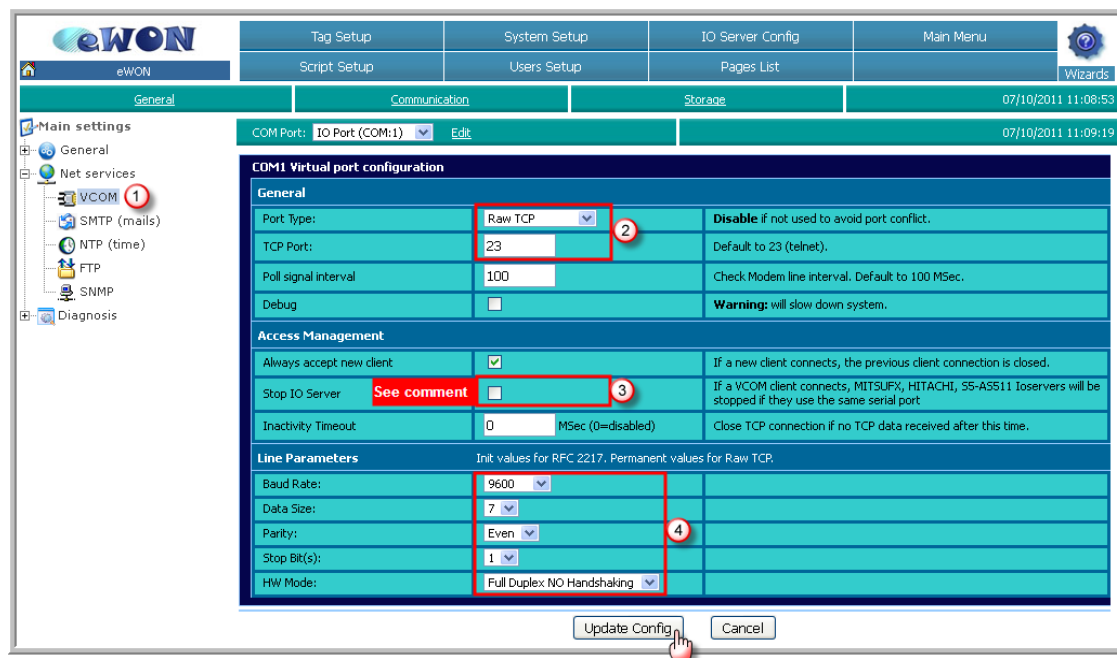

Parameters requiring attention are:

In frame 2

Port type: **Raw TCP**

TCP Port: **23**

In frame 3

Stop IO server: unchecked by default

You should check this option if the eWON is also polling data from the Mitsubishi PLC to stop the IO server during remote maintenance. Failing to do so will not allow remote connection while the serial port will be busy with the polling activity. When ticked, the option stops the IO server activity during remote connection and restores it automatically as soon as the port is released.

In frame 4

Baud Rate: **9600**

Data size: **7**

Parity: **Even**

Stop bits: **1**

HW Mode: **Full Duplex NO Handshaking**

2. Save your settings by clicking on **Update Config**
3. Connect the eWON serial port to the serial port of the PLC (using the serial cable as shown in § 12 Appendix 4 – Serial cable information).
4. End of serial link configuration.

6.2.2 Serial connection to Q-Series

1. For the **Q-Series**, configure VCOM properties using the following properties:

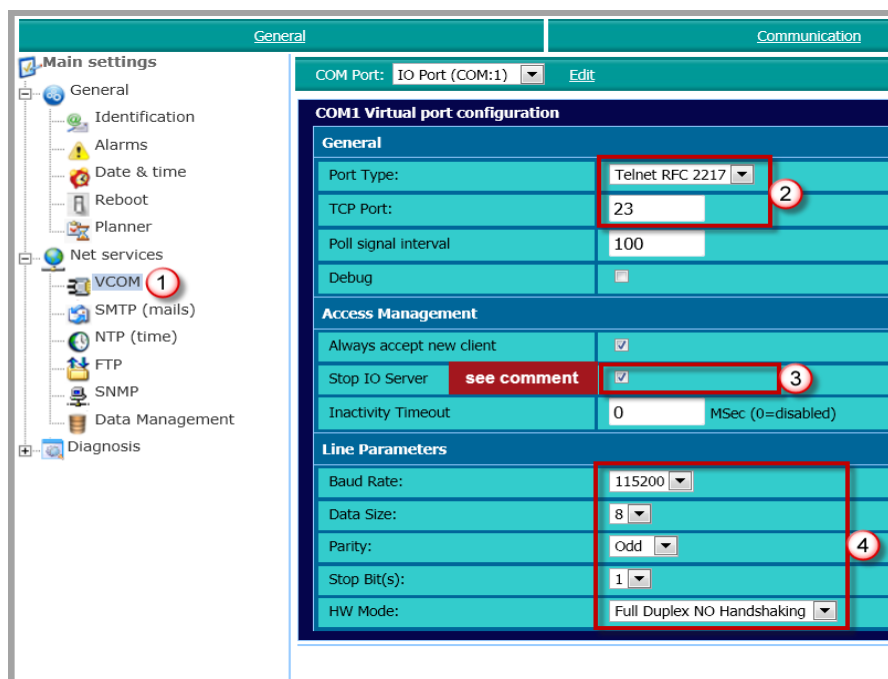

Parameters requiring attention are:

In frame 2

Port type: **Telnet RC 2217**

TCP Port: **23**

In frame 3

Stop IO server: unchecked by default

You should check this option if the eWON is also polling data from the Mitsubishi PLC to stop the IO server during remote maintenance. Failing to do so will not allow remote connection while the serial port will be busy with the polling activity. When ticked, the option stops the IO server activity during remote connection and restores it automatically as soon as the port is released.

In frame 4

settings of the serial com on the PLC side, given values are just one possibility

Baud Rate: **115200**

Data size: **8**

Parity: **Odd**

Stop bits: **1**

HW Mode: **Full Duplex NO Handshaking**

2. Save your settings by clicking on **Update Config**
3. Connect the eWON serial port to the serial port of the PLC (using the serial cable as shown in § 12 Appendix 4 – Serial cable information).
4. End of serial link configuration.

6.3 Ethernet link configuration

- Tips -

As of firmware v12, there is a PLC Discovery feature inside the eWON. This allows the automatic discovery of PLC (linked to the eWON) on the network while you are connected through Talk2M. No need to set the IP of the PLC in the same range than the IP of the eWON.

For more information, please refer to [AUG-070: PLC Discovery through Talk2M](#)

If firmware version is lower than 12, please follow the procedure hereunder.

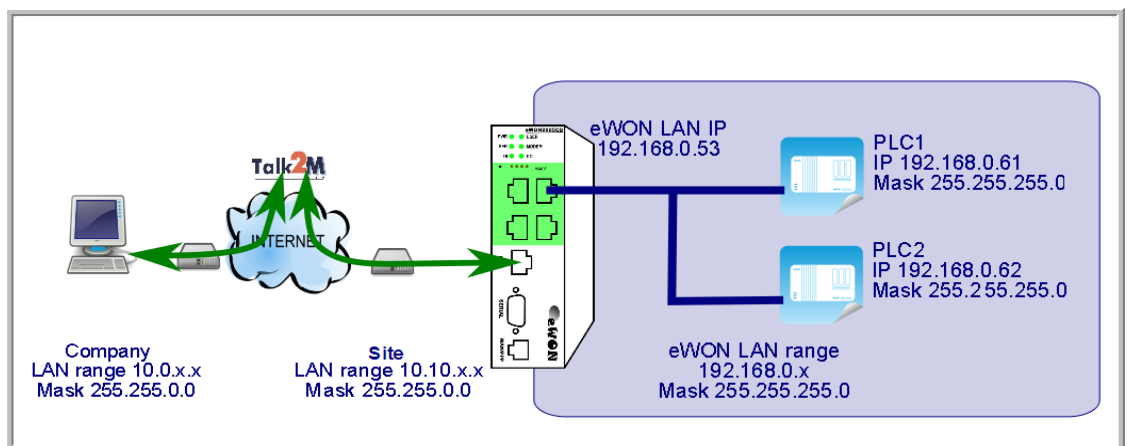

1. If your eWON runs a firmware 6.2s1 or greater (see note) there is nothing to do but making sure that the PLC IP address is in the same range than the LAN IP of the eWON. In our example, the IP address of the PLC is 192.168.0.61.

Note 1: From eWON firmware version 6.2s1 onwards, the **Plug'nRoute** function automatically configures the Ethernet routing. With this configuration, it is no longer necessary to set the eWON address as Gateway into the PLC.

Note 2: The eWON types with 4 LAN ports (2005CD or 4005CD) can be connected to the Ethernet port of the PLC directly. Whereas the eWON types with a single LAN port (2101CD or 4101CD) need to be connected with a **crossed cable** (single PLC) or an **external switch** (multiple PLC).

6. Linking eWON and PLC

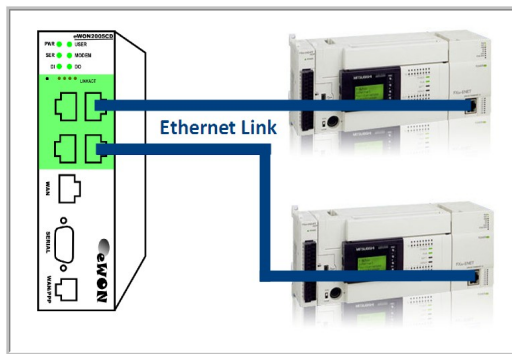

EWON 2005-Series

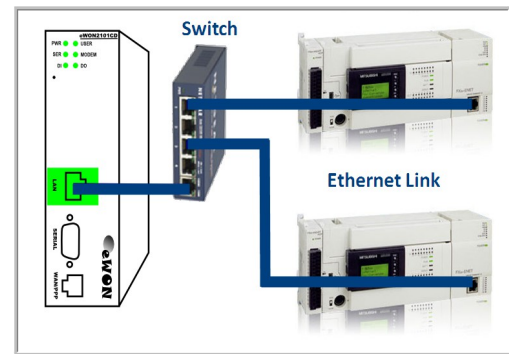

eWON 2101-Series

2. End of Ethernet link configuration.

7. PLC software mapping configuration

7.1 Serial connection

The serial connection with a Mitsubishi PLC requires the creation of a virtual port on your PC. To create this virtual port you need to install the eVCom application. You can download this application from <http://support.ewon.biz/softwares.htm>.

7.1.1 Creating a virtual serial port on your PC

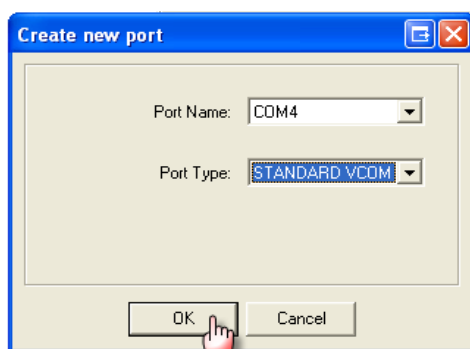
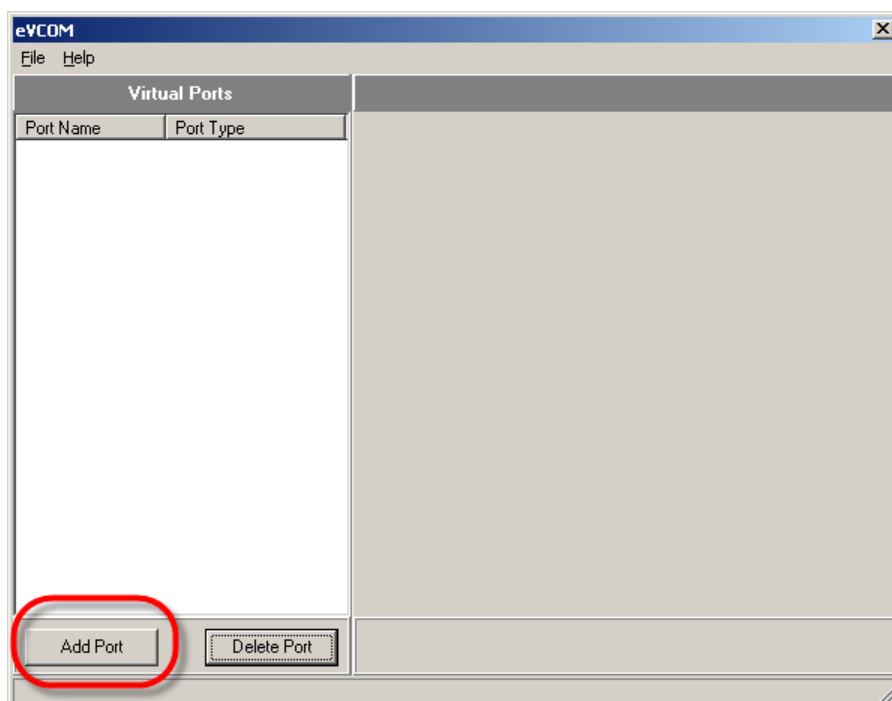

Start eVCOM on your PC and create a new virtual port, by clicking Add Port:

A dialog box invites you to choose the COM Name and the Port Type. In the Port Name dropdown, eVCOM shows only ports that are available on your machine. In our example, we selected **COM4** (FX-Series) and **COM5** (Q-Series) to keep away from the normal ports of the machine. Select **STANDARD VCOM** as Port Type and click **OK**.

For the **FX-Series**, configure the virtual port parameters as follows:

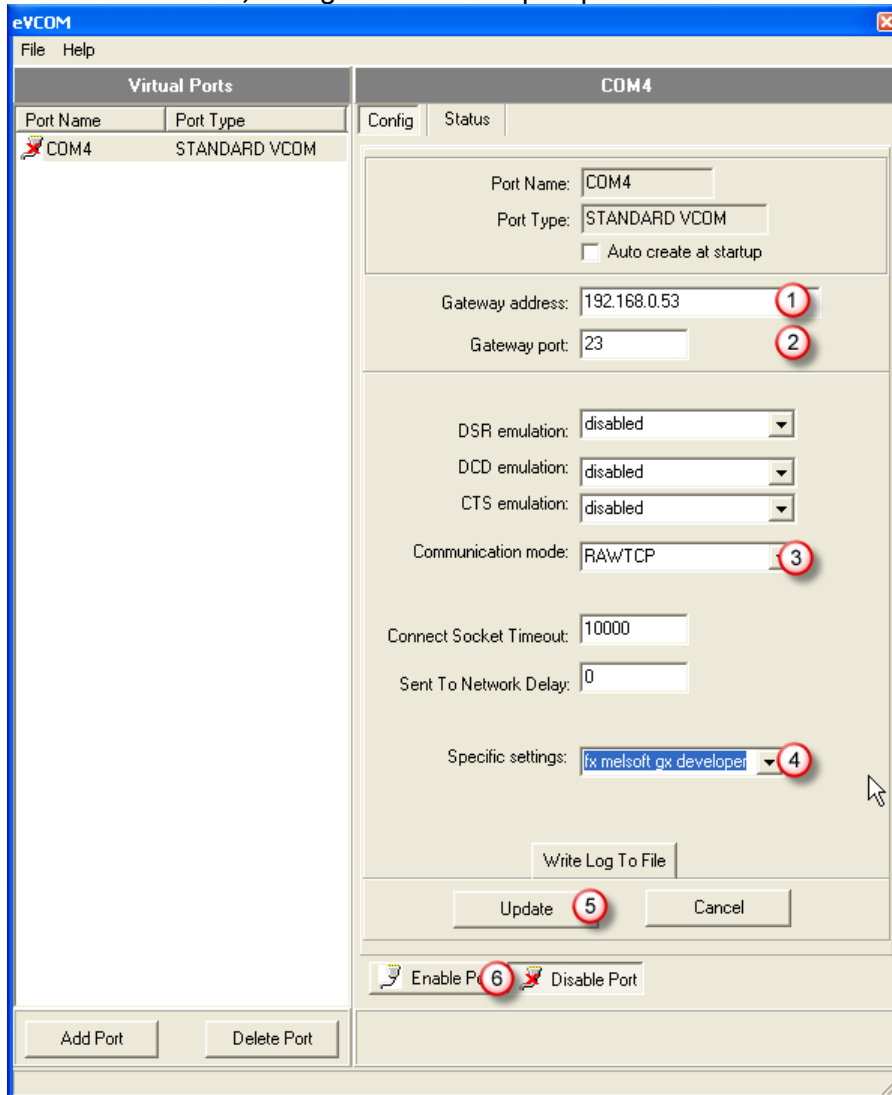

1. The *Gateway address* is the IP address where you can reach the eWON (through Talk2M). If your eWON is on your LAN network, you will use its LAN address, in this first example it is 192.168.0.53.
2. Set *Gateway port* to **23**.
3. The *Communication mode* to **RAWTCP**.
4. Set Specific settings to **fx melsoft gx developer**
5. Click **Update**.
6. Click **Enable Port**.

For the **Q-Series**, configure the virtual port parameters as follows:

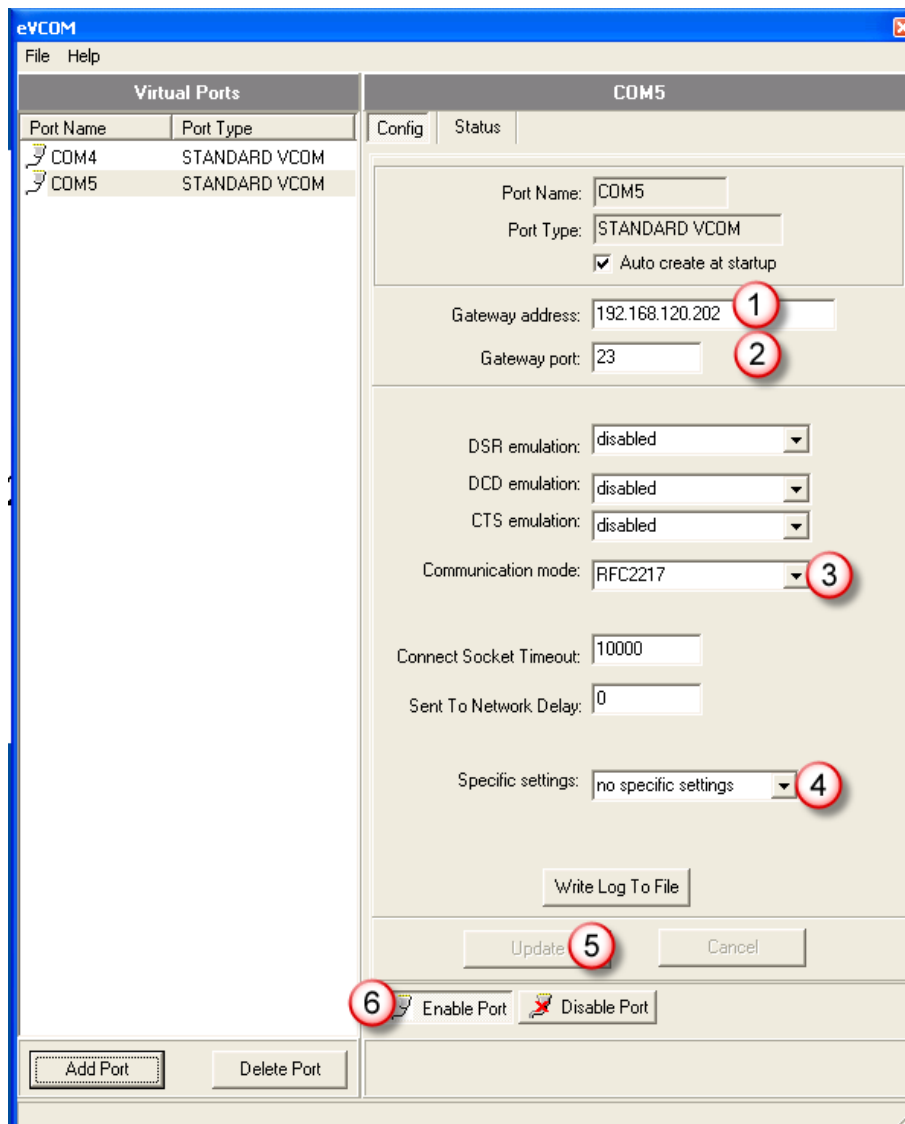

1. The *Gateway address* is the IP address where you can reach the eWON (through Talk2M). If your eWON is on your LAN network, you will use its LAN address, in this second example it is 192.168.120.202.

2. Set *Gateway port* to **23**.

3. The *Communication mode* to **RFC2217**.

4. Set Specific settings to **no specific settings**

5. Click **Update**.



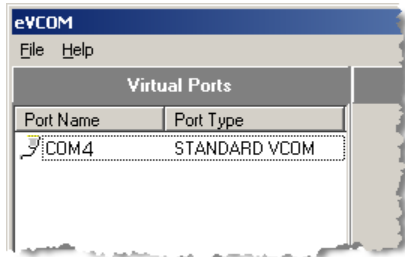

6. Click **Enable Port**.

7. PLC software mapping configuration

Once enabled, eVCOM will show your new virtual COM port like following:



Key to status icons (left from com port name):

-  enabled
-  disabled
-  communication OK
-  communication with errors

7. Leave eVCOM open, port enabled until you don't need the communication anymore.
Note: If you try to close eVCOM while the virtual port is still enabled, the program asks you if you want to minimize it (all functions active) or if you want to really quit it. If you click on **Really Quit** the software closes the port, retains the existing parameters until you reopen a new session.

7.1.2 Mitsubishi MelSoft GX configuration

1. Open Melsoft GX and open your project.

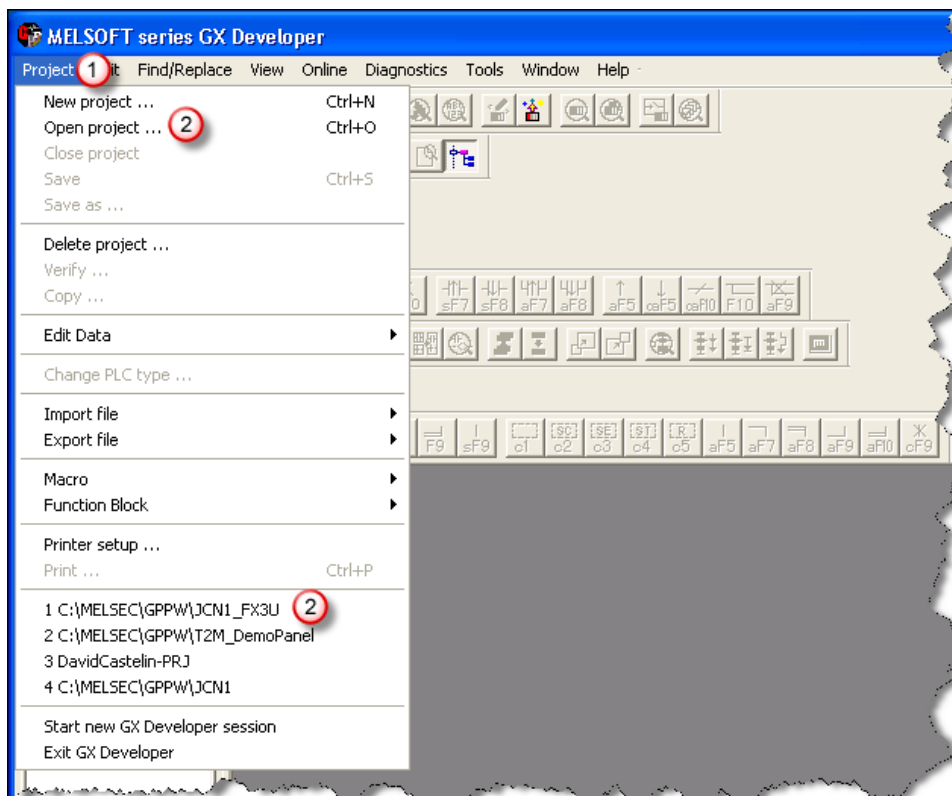

7. PLC software mapping configuration

2. Click **Online** > **Transfer Setup** from the menu bar

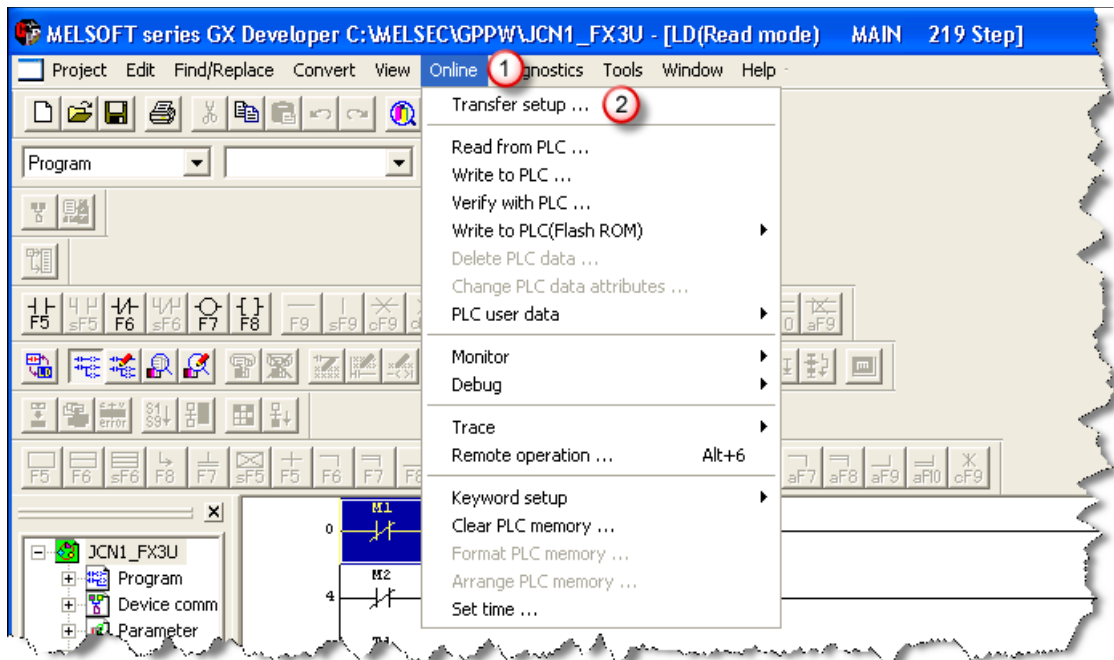

3a. For the **FX-Series**, set the serial parameters as shown below and click **OK**.

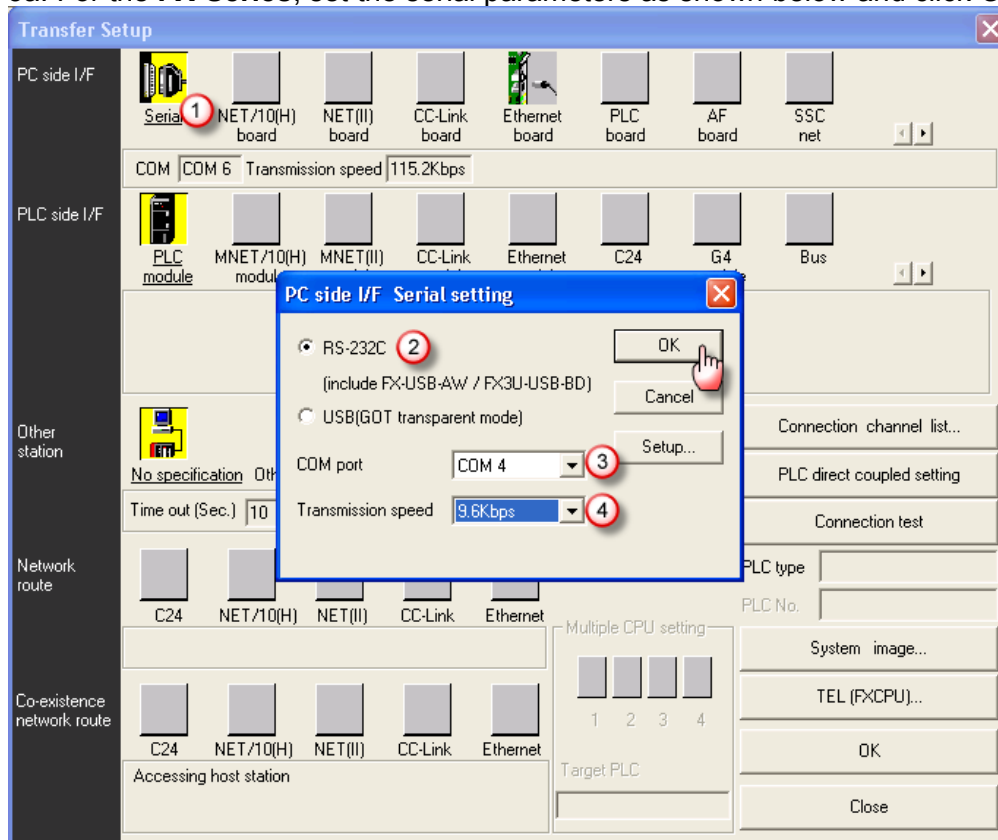

> In **Transmission speed (4)** put 9.6Kbps

7. PLC software mapping configuration

3b. For the **Q-Series**, set the serial parameters as shown below and click **OK**.

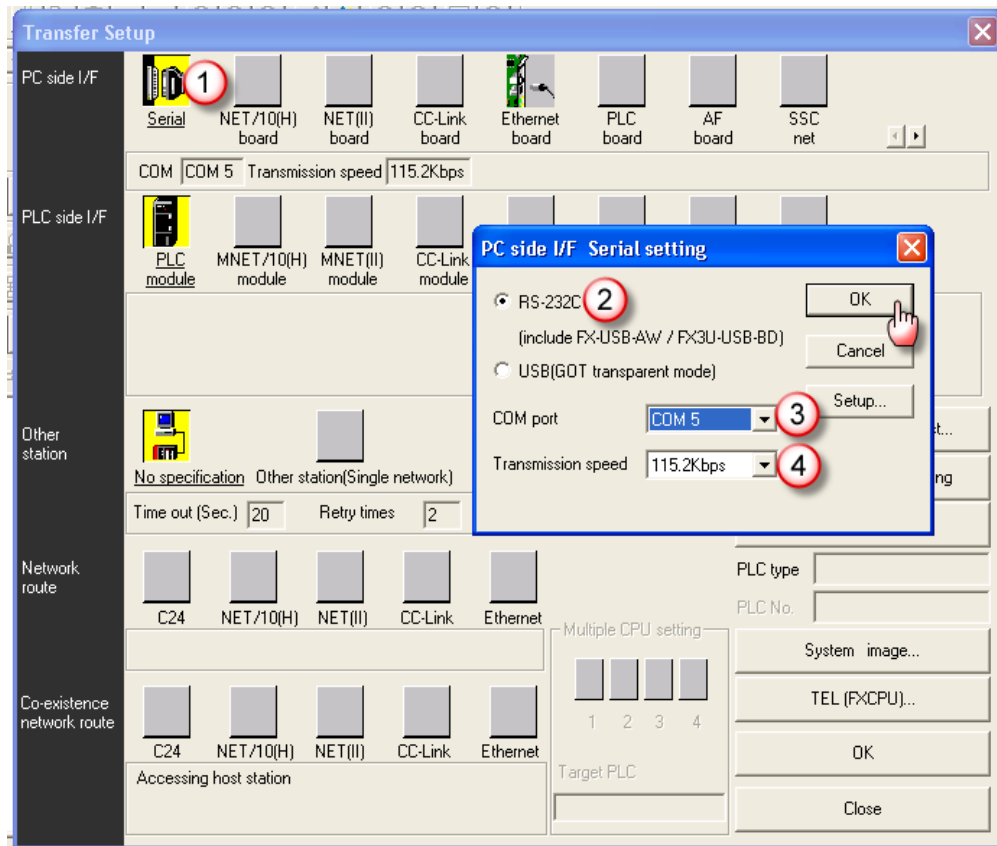

> In **Transmission speed (4)** put the setting corresponding to the PLC, in our example it is 115.2Kbps (but it might be another value).

4. Test the connection by clicking **Connection test**.

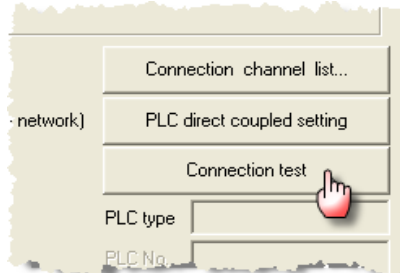

Success message on the FX-Series

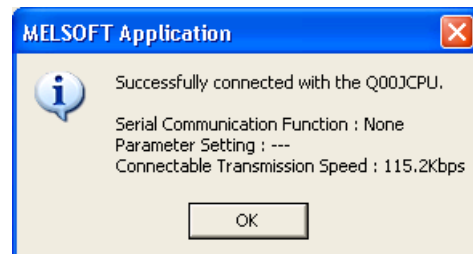

Success message on the Q-Series

Note: To test the communication remotely, you need to establish the Talk2M VPN bridge first (as explained in [Step 6](#)).

5. End of software mapping in serial connection.

7.2 Ethernet connection

7.2.1 Mitsubishi MeSoft GX configuration

1. Open Melsoft GX and open your project (as described in § 7.1.2 Mitsubishi MeSoft GX configuration)
2. Click **Online > Transfer Setup** from the menu bar.
3. Set the Ethernet parameters like shown below and click **OK**

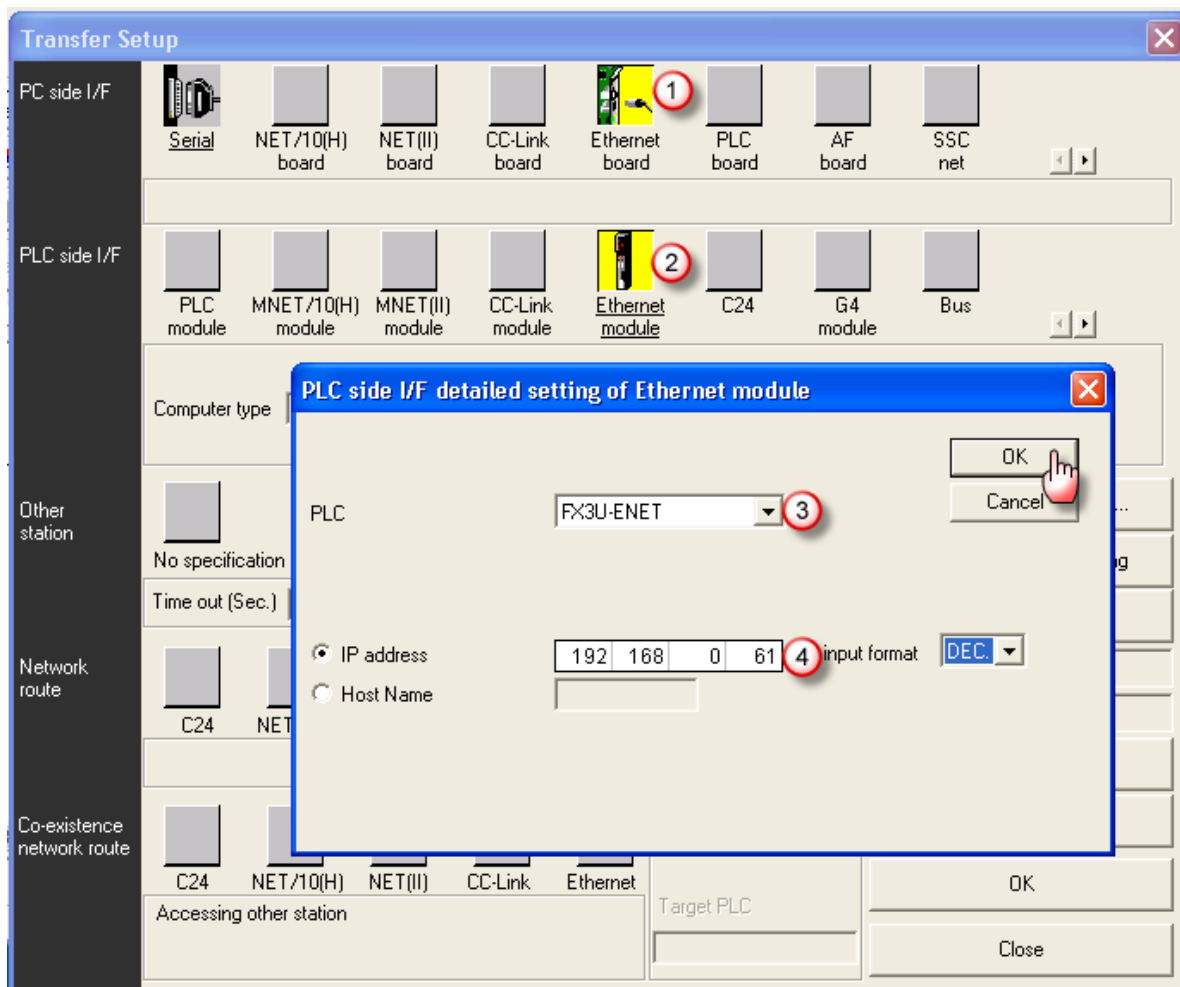

Applicable parameters are:

PC side I/F = just select **Ethernet** board,

Note: on some Mitsubishi software versions (like GX IEC), an interface is asking you to define a station number, which is the the station number of the PC that has to be different from the PLC station number.

PLC side I/F = Click on **Ethernet module** and configure as shown above:

PLC > type of the Ethernet module (normally part of your project)

IP Address > IP address of the PLC (in our case 192.168.0.61).

4. Test the connection by clicking **Connection test**.

Note: To test the communication remotely, you need to establish the Talk2M VPN bridge first (as explained in [Step 6](#)).

5. End of software mapping in Ethernet connection.

8. PLC remote access

1. Establish the remote connection to the eWON as explained in [Step 6](#) of the eWON configuration part.
2. Once the Talk2M VPN tunnel towards the eWON is established by eCatcher, start the MelSoft GX software.
3. In MelSoft GX select **Online > Remote operation**
4. Allow enough time for the connection to actually take place, especially when using a modem connection since the throughput may be relatively slow.
5. As soon as the connection is working, it appears in the status bar of MelSoft GX.
6. You can now work in remote programming mode.
Once you finished your work with MelSoft GX:
 - Go Offline and close
 - Terminate the remote connection to the eWON explained in [Step 7](#) of the eWON configuration part.
7. End of PLC remote access.

9. Troubleshooting

9.1 Cannot reach serial PLC?

If you cannot reach the serial PLC connected to the eWON then verify the following:

- Check [serial dip switch positions](#) of the eWON (FX-Series is RS422 while Q-Series is RS232)
- Check [VCOM configuration in eWON page](#)
- Open the eWON Event Log [**Main Menu, Diagnostic, Event Log**] to check for error messages.
- In eVCOM check if the correct IP address has been configured: You must use either the eWON LAN IP address or the eWON VPN IP address.

9.2 Cannot reach Ethernet PLC?

To be able to reach the Ethernet PLC, the following conditions must be fulfilled:

- Reboot the PLC after IP address change.
- Check that the network LED are lighting at both ends. If they aren't, it means there is an issue with the Ethernet cable(s). If you use an eWON having a single Ethernet LAN port (no integrated switch), then you have to use either a ***crossed*** Ethernet cable (point-to-point with single PLC) or an intermediate switch (multiple PLCs).
- You might have a mismatch between the actual IP configuration of the eWON and the eWON LAN IP address configured as Remote Network in your Talk2M account. You can check, and if necessary, modify these settings, in eCatcher. Under the eWON list select the Name of the remote connection and click on the ***Detail*** button.

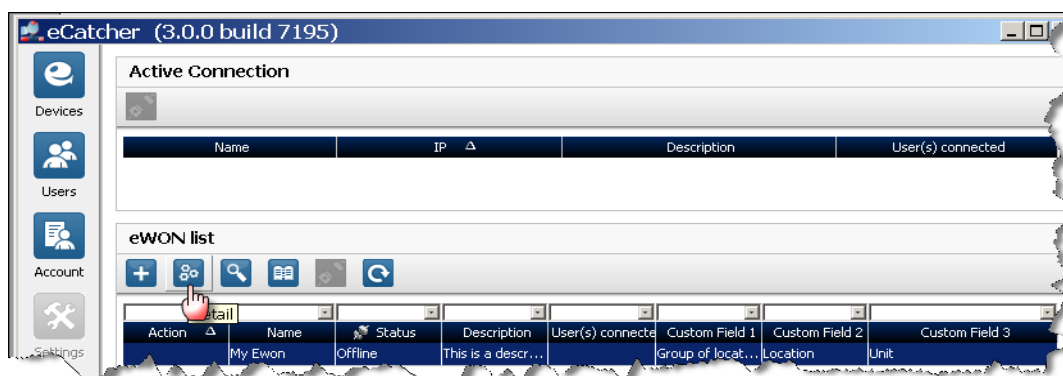

The eWON Detail window will open:
 Here you will find the different information you entered earlier. The Remote Network is specified under the Remote connection section.

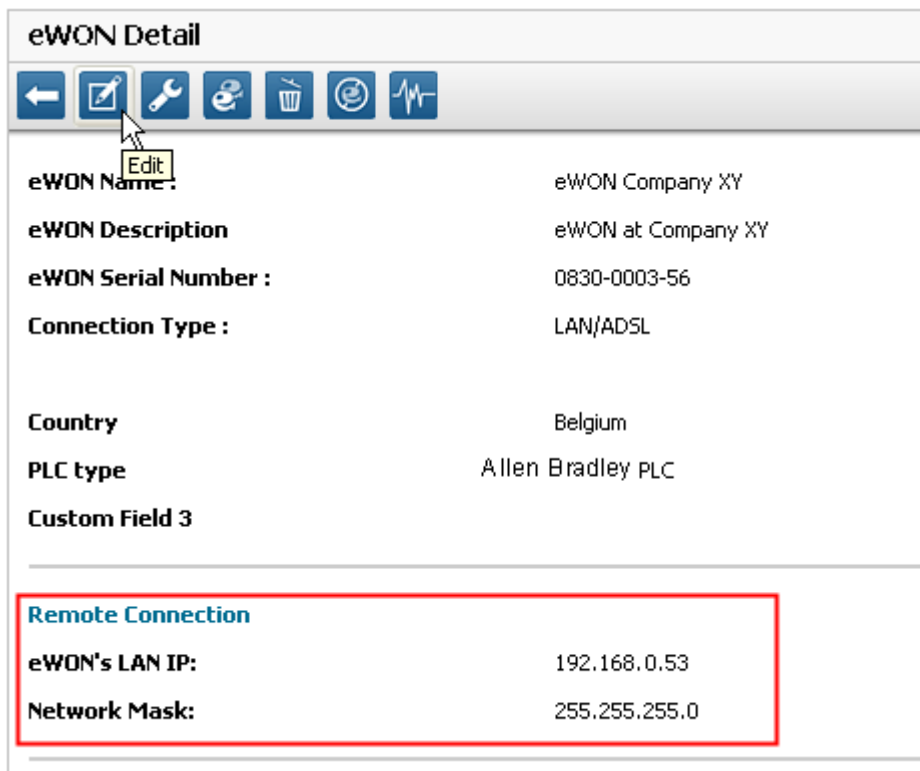

To change the Remote Connection settings, click on the Edit button on the top of the page.

Once the modification is finished, click on the Save button which is displayed on the top of the window when in edit mode. After the change you would then have to save and **Disconnect** and **Connect** the VPN bridge to the eWON for Talk2M to take the modification into account.

The remote PLC network must be in a different range than the company network on which your PC is connected (see § 5.1 Step 1: [Setting IP address of eWON LAN](#)).

10. Appendix 1 – Specifics for Modem connections

10.1 General

The basic configuration principles remain the same except for typical modem settings. Allow enough time for tasks to be executed when you use a modem link. In the following explanations, we took the most current example of GPRS/Edge modem. Extrapolating to other modem technologies is rather straight forward. Only those steps that are different from the LAN/WAN connection are addressed.

10.2 Configuring the eWON for Internet connection (Step 2)

1. In the Internet configuration wizard of the eWON, select **Modem Connection** option and, depending on the modem installed in the eWON, the interface asks the user to fill out the different parameters of the relevant modem. Fill out the different fields (PIN code, APN and user name/password) according those you received from your Service Provider. For most Service Providers, User Name and Password can be left empty. Click **Next**.

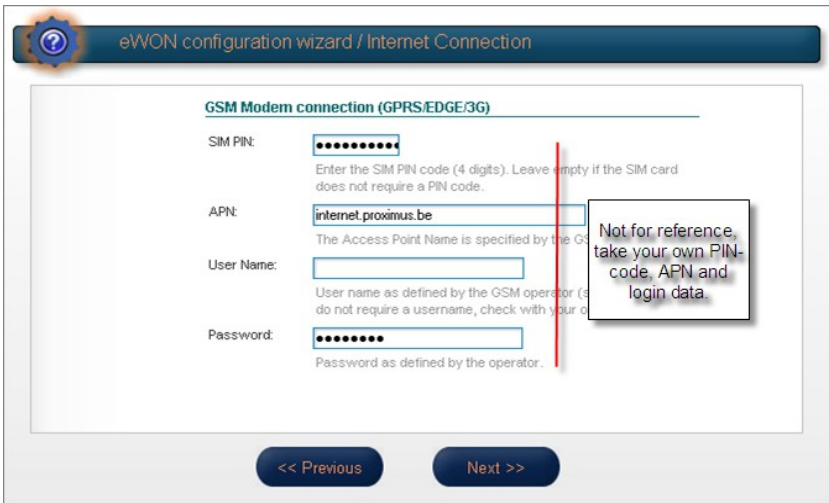

eWON configuration wizard / Internet Connection

GSM Modem connection (GPRS,EDGE,3G)

SIM PIN:
Enter the SIM PIN code (4 digits). Leave empty if the SIM card does not require a PIN code.

APN:
The Access Point Name is specified by the GSM operator.

User Name:
User name as defined by the GSM operator (some operators do not require a username, check with your operator).

Password:
Password as defined by the operator.

Not for reference, take your own PIN-code, APN and login data.

<< Previous Next >>

2. Configure how the eWON should go online, and click **Next**.

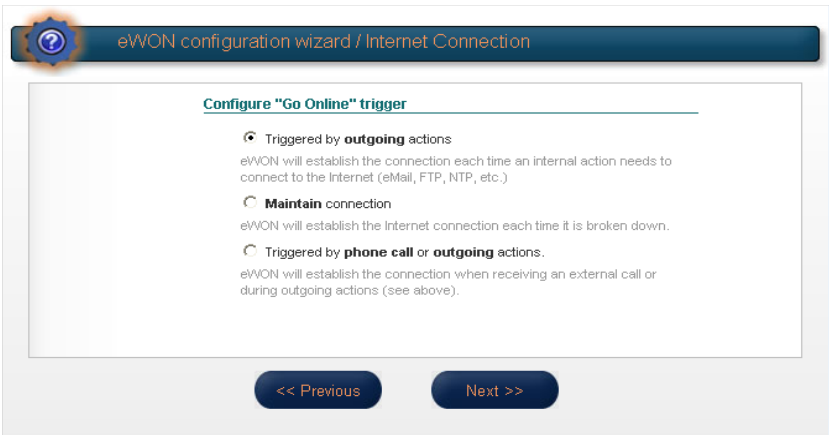

eWON configuration wizard / Internet Connection

Configure "Go Online" trigger

Triggered by outgoing actions
eWON will establish the connection each time an internal action needs to connect to the Internet (eMail, FTP, NTP, etc.)

Maintain connection
eWON will establish the Internet connection each time it is broken down.

Triggered by phone call or outgoing actions.
eWON will establish the connection when receiving an external call or during outgoing actions (see above).

<< Previous Next >>

3. In most cases, it will be **Triggered by outgoing actions**. This option is needed to be able to use the Wake-Up function. Only check **Maintain connection** if you want to use a permanent connection to your eWON device (which can be very expensive using a GPRS/Edge line).
4. Configure your online time parameters, and click **Next**

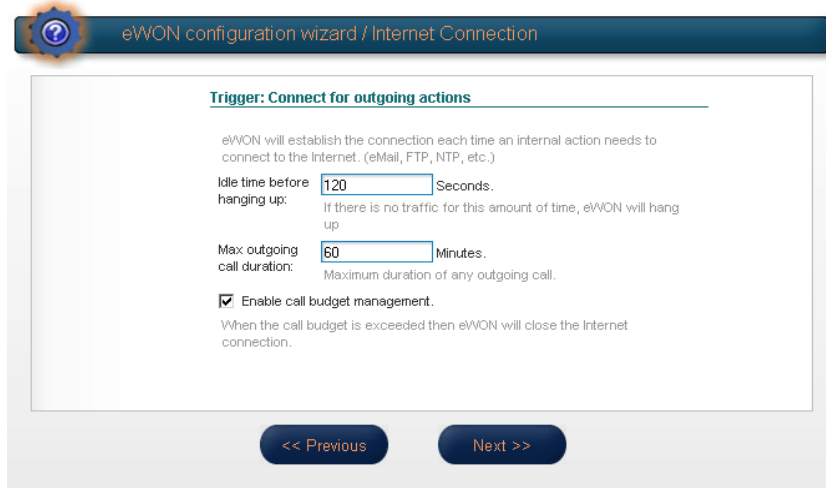

In most cases, you can leave the default parameters.

The **Max outgoing call duration** is set by default to 60 minutes. The eWON will drop the Talk2M connection after 1 hour. If you need longer connection times, enter a higher value or set it to 0 for no limit.

By default, the **Idle time before hanging up** is set to 120 seconds. You can leave this value as is. In fact, it is not a useful parameter for a Talk2M connection because a VPN life bit is periodically exchanged preventing connection interruptions due to idle times.

5. End of Step 2 in Appendix 1.

10.3 Creating the eWON in your Talk2M account (Step 3)

1. In the creation process of the eWON in your Talk2M account, the sole additional steps are:
 - specifying the connection type (in our example GPRS/Edge)

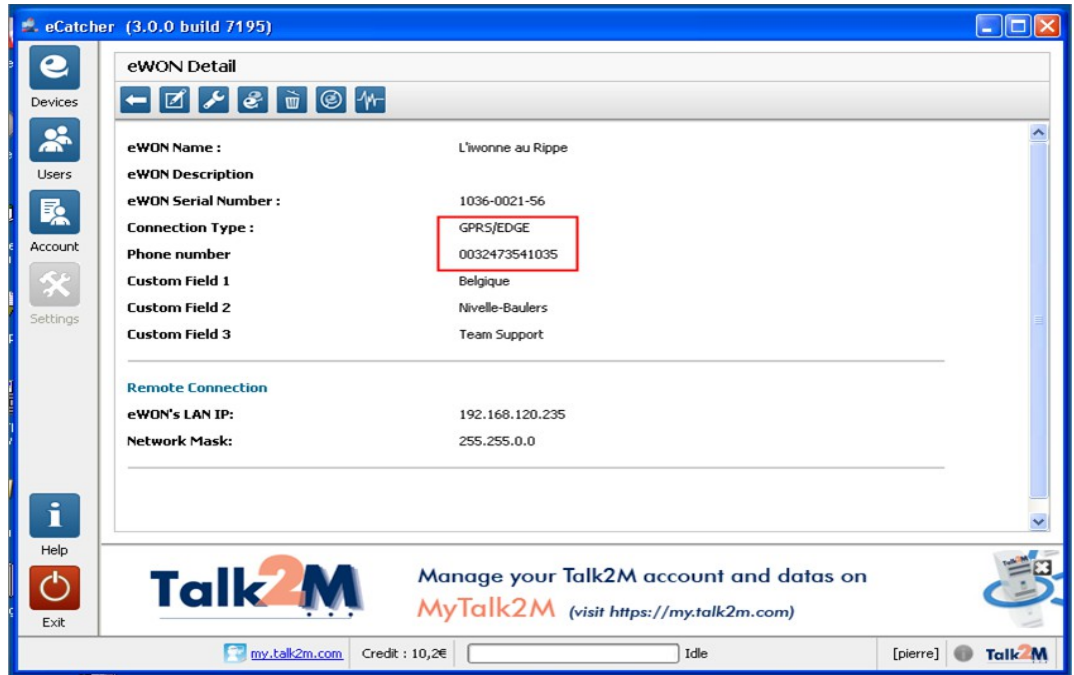

- entering the phone number (including 00AB, AB being the country code)

2. End of Step 3 in Appendix 1.

10.4 Connecting the eWON remotely (Step 6)

1. If you use an eWON GPRS, then you probably configured the eWON not to stay connected all the time to the Talk2M server. Before being able to connect to the eWON over Talk2M you will first need to wake-up the modem of the eWON. To do this, click on the **Wake-up** icon in front of the eWON name as shown in the following picture:

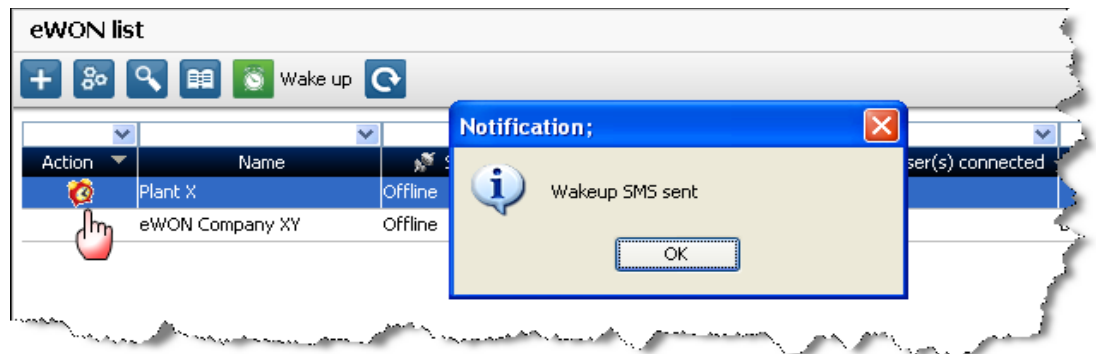

2. Talk2M sends an SMS (text message) to the eWON to ask the eWON to start its Internet connection and to connect to the Talk2M server. This can take up to several minutes; do not interfere until this process is completed.
Note: You do not necessarily need Talk2M to send the wake-up SMS to the eWON. You can do this using your own GSM (cellular phone). All you need is to have the dial number of the eWON by the hand and to send the following SMS (text-message) to it: [Talk2MConnect] (without brackets).
3. Once the modem is online, the green **Connect** icon is shown to allow to bridge the VPN tunnel.
4. You can now click on the **Connect** button as explained in the LAN/WAN procedure to establish the remote connection.
5. Once the VPN tunnel is bridged the red **Disconnect** icon is shown to allow you to cut the bridge of the VPN connection.

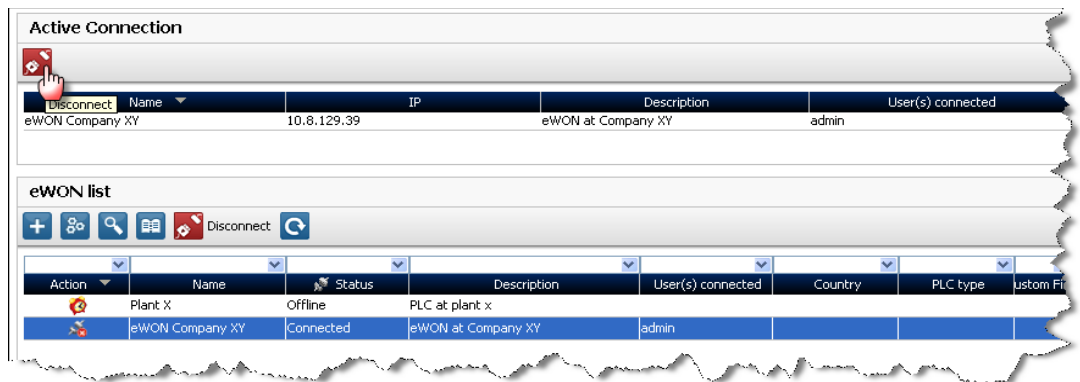

6. End of Step 6 in Appendix 1.

10.5 Terminating the remote connection (Step 7)

If the eWON to which you were connected uses a Modem connection for the Internet access, then you probably want to close the Internet connection of the eWON (in order to save GPRS communication costs). This is done with eCatcher.

Note that there are 2 distinct notions to be considered: **Connect / Disconnect** that applies to bridging the VPN tunnel and **Go Offline** that closes the VPN link and hence the modem connection (on hook)

1. Click on **Disconnect** to cut the VPN bridge.

10. Appendix 1 – Specifics for Modem connections

2. Right-click on the Online icon in front of the eWON. In the context menu click on the **Go offline** button to send the disconnect request to the eWON. The eWON will then close its Internet connection and after a while the eWON will be displayed as offline in your Talk2M account.

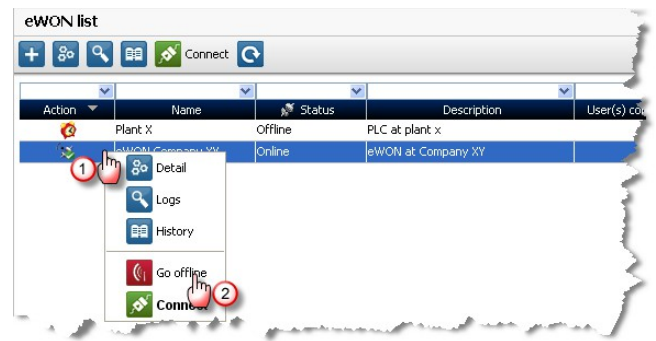

3. End of Step 7 in Appendix 1.

11. Appendix 3 – Security aspects

11.1 Login security

A good security practice consists in modifying the login and password of the default super user adm/adm (this default super user cannot be deleted). Modifying the default super user is done by clicking on **Configuration, Users Setup** button on the main menu of the eWON web page.

11.2 Traffic security

Since eWON firmware version 6.2s1 (see note), when the Talk2M wizard is executed, the WAN Security setting is set automatically to **Discard all traffic excepted VPN and initiated traffic**. This is preventing third party traffic to interact with your private traffic.

If, for any reason, your eWON runs an earlier firmware version (not recommended) OR that you want to check the WAN protection status, you can do it using the following path: **Configuration, System Setup, Communication, Networking Config, Security**.

Check that the **Discard all traffic excepted VPN and initiated traffic** check-box is

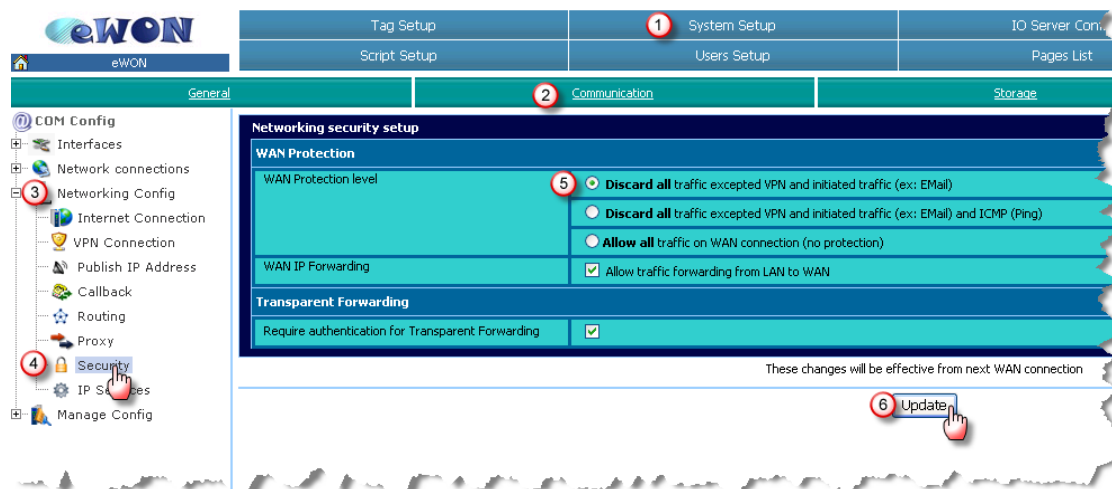

ticked.

If the eWON is configured to use a modem to go out on the Internet, then the WAN connection is the GPRS/EDGE connection. **This type of access definitely requires protection**. If the eWON is configured to use its second Ethernet Interface to go out on the Internet, then the WAN connection is the Ethernet WAN port that uses the company infrastructure and benefits from the IT protections in place. Hence, this type of access is less exposed to security issues.

Note: The changes applied on this page will only be effective from the next WAN connection. So from the next GPRS connection, or after an eWON reboot if you use the 2nd Ethernet port of the eWON for the Internet connection.

12. Appendix 4 – Serial cable information

12.1 FX-Series - RS422

The serial link between a Mitsubishi **FX-Series** PLC and the eWON is normally a RS422 connection. The FX PLC connector is a Mini-DIN8 connector.

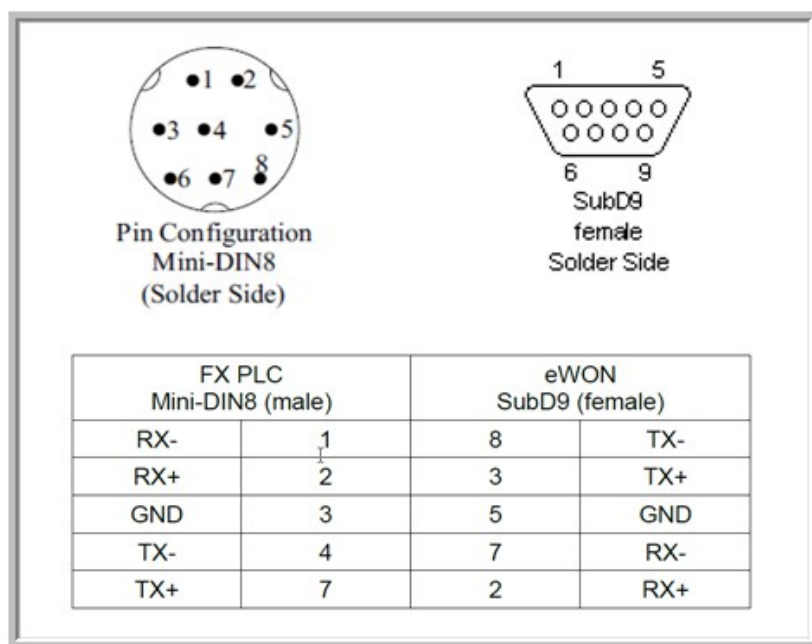

RS422 eWON dip-switch settings

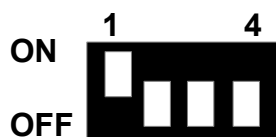

Alternatively, the **FX-Series** can be connected using a RS422 to RS232 converter cable. This cable is red and has reference SC-09.

RS232 eWON dip-switch settings for use with SC-09 converter (all OFF)

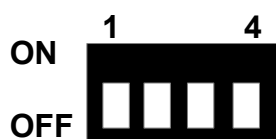

12.2 Q-Series - RS232

The serial link between a Mitsubishi **Q-Series** PLC and the eWON is an RS232 connection. The Mitsubishi cable reference is QC30R2.

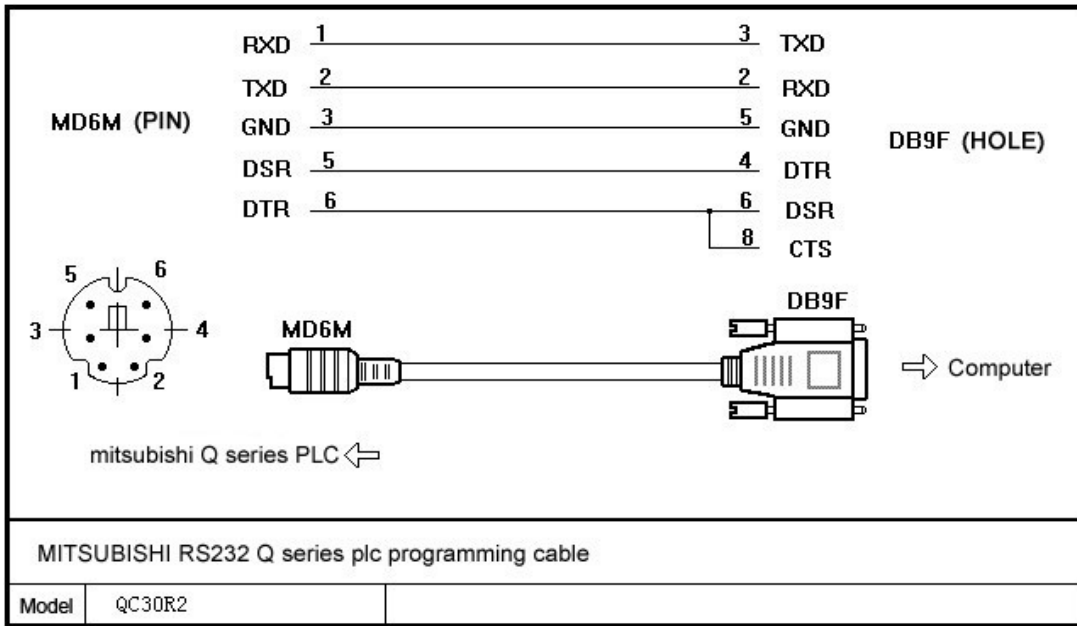

RS232 eWON dip-switch settings (all OFF)

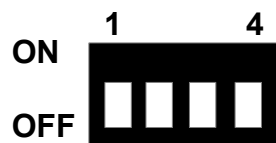

Revision history

Revision Level	Date	Description
1.0	02/12/11	First issue
1.1	29/11/12	Add Telnet RFC 2217 variant for Q-Series
1.2	15/12/16	Added "PLC Discovery" to Chapter 6.3

-
- i Microsoft, Internet Explorer, Windows and Windows XP are either registered trademarks or trademarks of Microsoft Corporation
 - ii Firefox is a registered trademark of the Mozilla Foundation

Document build number: 67

Note concerning the warranty and the rights of ownership:

The information contained in this document is subject to modification without notice. The vendor and the authors of this manual are not liable for the errors it may contain, nor for their eventual consequences.

No liability or warranty, explicit or implicit, is made concerning quality, the accuracy and the correctness of the information contained in this document. In no case the manufacturer's responsibility could be called for direct, indirect, accidental or other damage occurring from any defect of the product or errors coming from this document.

The product names are mentioned in this manual for information purposes only. The trade marks and the product names or marks contained in this document are the property of their respective owners.

This document contains materials protected by the International Copyright Laws. All reproduction rights are reserved. No part of this handbook can be reproduced, transmitted or copied in any way without written consent from the manufacturer and/or the authors of this handbook

eWON sa, Member of ACTL Group.