



## Installation Guide

IG 022 / Rev. 1.7

# eWON COSY 131

This installation guide describes the hardware of the eWON COSY 131 and explains how to get started with the embedded web site.





# Table of Contents

- 1. Product Summary ..... 4**
  - 1.1. Introduction ..... 4
  - 1.2. Concept of the eWON COSY 131 Family ..... 4
  - 1.3. General specification of the hardware platform ..... 4
  - 1.4. Typical applications ..... 5
  - 1.5. Type and Part Numbers ..... 5
- 2. Safety, Environmental & Regulatory Information ..... 6**
  - 2.1. Scope ..... 6
  - 2.2. Power supply ..... 6
  - 2.3. Applicable Directives, Standards and Compliance ..... 6
    - 2.3.1. Applicable European Directives ..... 6
    - 2.3.2. Applicable Safety Standards ..... 7
    - 2.3.3. FCC Compliance ..... 7
    - 2.3.4. Certifications ..... 7
  - 2.4. Field implementation & environmental conditions ..... 7
    - 2.4.1. Ingress Protection ..... 7
    - 2.4.2. Mounting Recommendations ..... 8
    - 2.4.3. Cabling rules ..... 10
    - 2.4.4. Environmental conditions ..... 10
    - 2.4.5. Earthing ..... 10
  - 2.5. Battery ..... 10
- 3. Hardware description ..... 11**
  - 3.1. Label ..... 11
  - 3.2. Mechanical dimensions ..... 13
  - 3.3. Overall description ..... 13
    - 3.3.1. Front ..... 13
    - 3.3.2. Upper side ..... 14
    - 3.3.3. Status LED (COSY 131 – All version) ..... 14
      - 3.3.3.1. WiFi Status LED (EC6133C) ..... 15
      - 3.3.3.2. Cellular Modem Status LED (EC6133D - EC6133E) ..... 15
  - 3.4. Radio communication models ..... 16
    - 3.4.1. COSY 131 with internal WiFi modem ..... 16
    - 3.4.2. COSY 131 with internal 3G+ Penta-band modem ..... 17
    - 3.4.3. COSY 131 with internal 4G JP Quad-band modem ..... 18
  - 3.5. LAN Switch Specifications ..... 19
    - 3.5.1. Boot process ..... 19
    - 3.5.2. LAN Switch configuration ..... 19
- 4. COSY IP Address & Access to the Web Configuration ..... 20**
  - 4.1. Factory Default IP settings ..... 20
  - 4.2. Powering ON ..... 20
  - 4.3. Connecting to the eWON COSY LAN IP Address ..... 20
  - 4.4. eWON COSY's Web Interface ..... 21
- 5. Troubleshooting ..... 22**
  - 5.1. Normal Boot Process ..... 22



## Table of Contents

- 5.2. Resetting the eWON COSY 131 ..... 22
  - 5.2.1. First Level Reset (user reset) ..... 22
  - 5.2.2. Second Level Reset (factory reset) ..... 22
- 5.3. Reset Impact Matrix ..... 23
- Appendix A - Connector Pinout & Related Specifications ..... 24**
  - A.1 - Main Connector ..... 24
  - A.2 - Specification of the External Power Supply ..... 25
  - A.3 - Digital Output & Digital Inputs ..... 25
  - A.4 - Supported Wireless WiFi Frequencies ..... 28
- Revision ..... 30**
  - Revision History ..... 30

## 1. Product Summary

### 1.1. Introduction

The present Installation Guide describes the hardware of the **eWON COSY 131** family.

The eWON Cosy 131 family is a set of industrial gateways/routers fully compatible with the Talk2M cloud connectivity services ([www.talk2M.com](http://www.talk2M.com)).

### 1.2. Concept of the eWON COSY 131 Family

The Cosy 131 is available in different versions depending on their communication media:

- Ethernet Switch                      **Cosy 131 Ethernet**
- WiFi & Ethernet Switch            **Cosy 131 WiFi**
- 3G+ & Ethernet Switch            **Cosy 131 Cellular 3G+**
- 4G & Ethernet Switch              **Cosy 131 4G JP**

### 1.3. General specification of the hardware platform

| Characteristic     | Value  |
|--------------------|--|
| Design             | Industrial design (24 VDC power supply, DIN Rail mounting, extended temperature)   |
| Processor          | ARM9   |
| Clock              | Backed up real time clock (RTC)<br>Backup battery lifetime has 10 years expectancy |
| Ethernet Interface | LAN Ethernet port 10/100 Mbps  |
| Digital Input      | 2  |
| Digital Output     | 1  |
| Mounting           | Latch for DIN rail EN50022-compliant   |

### 1.4. Typical applications

- Remote Access of Ethernet & USB devices using Talk2M connection
- Industrial VPN router

## 1.5. Type and Part Numbers

The available part numbers are:

| Part Number  | Type     | Description                                     |
|--------------|----------|---|
| EC61330_00MA | COSY 131 | LAN/WAN – Ethernet Only 4-Port Switch           |
| EC6133C_00MA | COSY 131 | LAN/WAN, WIFI – Ethernet Switch                 |
| EC6133D_01MA | COSY 131 | LAN/WAN, 3G+ Penta-band - Ethernet Switch       |
| EC6133E_00MA | COSY 131 | LAN/WAN, 4G Quad-band (Japan) - Ethernet Switch |

*Table: List of the available part numbers*

**- Note -**

*The MA suffix means Multiple languages A (UK, FR, DE, ES, IT)*

*The part number syntax is explained in [3.1. Label](#)*

## 2. Safety, Environmental & Regulatory Information

### 2.1. Scope

The present chapter addresses Safety, Environmental & Regulatory Information for the eWON Cosy 131 family.

### 2.2. Power supply

The external power supply is a third party device that is not part of this certification.

The device shall be powered by a LPS power supply certified according to IEC/UL60950-1 or Class 2 per NEC (See annex [A.2. Specification of the External Power Supply](#) for detailed information).

### 2.3. Applicable Directives, Standards and Compliance

The product described in the present Installation Guide complies with the CE, RE directives and the FCC regulations related to the wireless modems.

The product described in the present Installation Guide belongs to class A Information Technology Equipment (ITE). In a domestic environment this product may cause radio interference in which case the user may be required to take appropriate measures.

#### 2.3.1. Applicable European Directives

The product described in the present Installation Guide is in conformity with the following EC directives:

- RoHS Directive 2011/65/EU
- EMC Directive 2014/30/EU
- RE directive 2014/53/EU (for versions including RF modems)  
The product conforms to the corresponding R&TTE articles:  
RF Spectrum efficiency, Art. 3(2); EMC, Art. 3(1)(b); Safety, Art. 3(1)(a);
- REACH Directive 2006/121/EC
- For COSY 131, Cellular 3G+ only: to comply with RE directive
  - Antenna must be mounted on a grounded plate

#### 2.3.2. Applicable Safety Standards

The product described in the present Installation Guide is in conformity with the following safety standards:

- IEC/EN 60950-1
- UL 60950-1

- CSA-C22.2 No 60950-1-07

#### 2.3.3. FCC Compliance

The product described in the present Installation Guide complies with Part 15 of the FCC Rules. Operating is subject to the following two conditions:

- This device may not cause harmful interference, and
- This device must accept any interference received, including interference that may cause undesired operation.

#### 2.3.4. Certifications

The product described in the present Installation Guide has been certified by authorized bodies:

- UL Certificate Of Compliance (CoC) for Ordinary Locations # E350576 for a TMRA of 60°C
- CB certificate # DK-42240-UL

These certificates can be downloaded as PDF files on the eWON Support web site:  
<https://ewon.biz/support/docs/cosy-131#5>

## 2.4. Field implementation & environmental conditions

### 2.4.1. Ingress Protection

The eWON COSY 131 has an IP20 protection grade. Therefore, the eWON COSY is NOT suited for outdoor mounting. It has to be integrated in an electrical cabinet, protected from excessive heat, humidity and dust. Do not push any sharp object into the air vents or openings of the equipment.

### 2.4.2. Mounting Recommendations

The normal mounting position of the eWON COSY is wall mounted on a horizontal [Omega type DIN-rail \(EN 50022\)](#).

- **Mounting the unit on DIN-rail**  
Pull the slide lock (located at the bottom of the back-side of the unit) downwards and present the unit in front of the DIN rail. Tilt the eWON upwards in order to hang it on the upper edge of the DIN rail by its hook. Gently tilt the unit downwards until it finds its

original position. Pull the slide lock upwards to fix and lock the unit on the DIN rail.

- **Removing the unit from DIN-rail**

Release the unit by pulling the slide lock downwards while gently tilting the unit upwards. Free the unit by unhooking it from the upper rail edge. See [2.4.2 Mounting instructions](#)

The product is intended to be mounted vertically, label on the right side

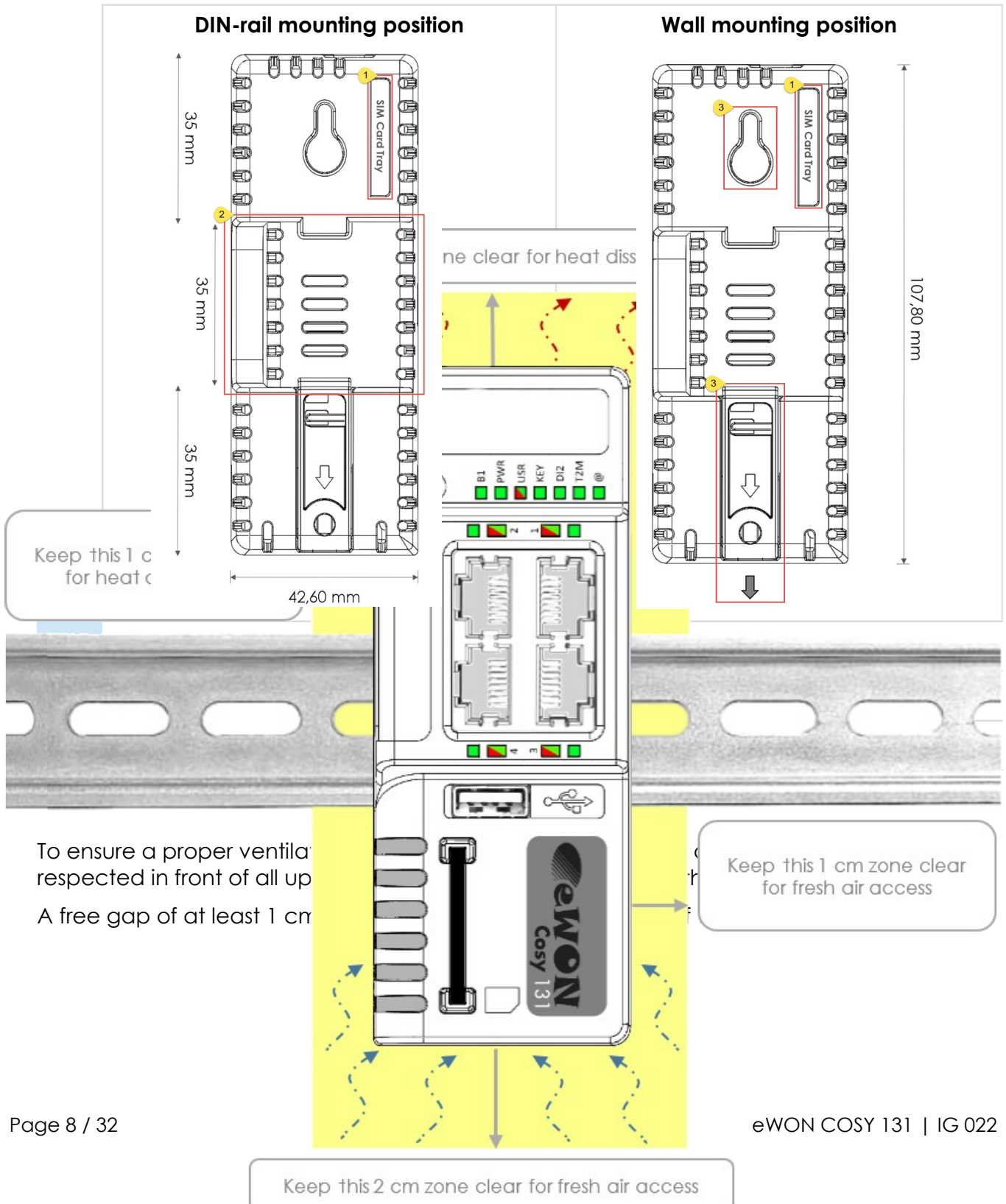



**- Caution -**

*In any other mounting position than the one explained here above, the specified temperature has to be derated to -25°C to +40°C.*

### **2.4.3. Cabling rules**

Shielded cables must be used for Ethernet and USB connectivity to comply with the EMC requirements.

USB cable must be:

- shorter than 3m

- USB 2.0 type A (on the eWON side)
- Minimum current per contact : 0.5A (or better)

#### 2.4.4. Environmental conditions

The equipment will operate properly within the following environmental limits if it has been correctly mounted according to the above mentioned recommendations:

|                     |                          |
|---------------------|--------------------------|
| Operating T°        | -25°C to +70°C           |
| Relative Humidity   | 10 to 95% non-condensing |
| Operating altitude  | Up to maximum 2000m      |
| Storage temperature | -40 to +70 °C            |
| Storage Humidity    | 10 to 95% non-condensing |
| Storage altitude    | Up to maximum 3000m      |

#### 2.4.5. Earthing

Earthing the eWON is necessary to eliminate unwanted transients (lightning protection) and to conform to the EMC requirements. Therefore, a functional earth (FE) terminal is available on the main connector as shown in [A.2. Specification of the External Power Supply](#).

Connect this terminal directly to allow impedance ground. Shielded cables have to be used for Ethernet and USB to comply with the EMC requirements.

### 2.5. Battery

The COSY contains a CR2032 battery. This battery is used to maintain the real time clock up-to-date even when the unit is not powered.

#### - Caution -

***Risk of explosion if battery is replaced by an incorrect type.***

*The battery is not intended to be replaced by the consumer. The product shall be returned to the manufacturer for replacement.*

## 3. Hardware description

### 3.1. Label

The identification label of the eWON COSY 131 is placed on the right hand side of the housing. The different parts of the label are described below:

| eWON COSY 131 Ethernet  | Label         | Description  |
|---|---------------|--|
|  <p>PN: EC61330_00MA/S<br/>COSY 131<br/>SN: 1501-0001-22<br/>MAC: 00 03.27 01 7B 8C<br/>Rating: 12-24V 2.5A</p> <p>Made in Belgium<br/>www.ewon.biz</p> <p>CE 0682<br/>UL LISTED ITE E350576<br/>FCC</p> | <b>PN</b>     | Part Number<br>(see syntax table below)  |
|   | <b>SN</b>     | Serial number on the form<br><br><b>YYWW-SSSS-PP</b><br><br><b>YY</b> = Year of production<br><b>WW</b> = Week of production<br><b>SSSS</b> = sequential mfg order<br><b>PP</b> = product type |
|   | <b>MAC</b>    | MAC address of the Ethernet adapter  |
|   | <b>Rating</b> | Power supply requirements  |
|   | <b>Marks</b>  | CE, UL,... logos if applicable   |

| Marks   | Description  |
|---|--|
|  | Conformité Européenne or European Conformity ( <b>EC</b> ) |
| <b>0682</b>   | Notified Body Number, warrantor of the CE Mark validation  |
|  | <b>UL Listed</b> ( <i>Underwriters Laboratories</i> )      |
|  | <b>FCC</b> <i>Federal Communications Commission</i>        |
|  | GITEKI (MIC) <i>Radio Act Conformity Mark</i>              |

Label can have variant marks depending on the model

|   |  |  |
|---|--|--|
|  <p>PN: EC6133C_00MA/S<br/>COSY 131 WIFI<br/>SN: 1501-0001-22<br/>MAC: 00:03:27:01:7B:8F<br/>WLAN: 00:07:80:01:CF:39<br/>Rating: 12-24V 2.5A<br/>Contains: FCC ID: 00QWF111<br/>IC: 5123A-BGTWF111<br/>UL LISTED ITE E350576</p> |  <p>PN: EC6133D_00MA/S<br/>COSY 131 3G<br/>SN: 1448-0005-22<br/>MAC: 00:03:27:01:7B:8E<br/>IMEI: 351579052837570<br/>Rating: 12-24V 2.5A<br/>Contains: FCC ID: R7HE910<br/>IC: 5131A-HE910<br/>UL LISTED ITE E350576</p> |  <p>PN: EC6133E_00MA/S<br/>COSY 131 4G JP<br/>SN: 1111-1111-22<br/>MAC: 00:03:27:02:6D:63<br/>IMEI: 357678050343997<br/>Rating: 12-24V 2.5A<br/>Contains: FCC ID: R7HE910<br/>IC: 5131A-HE910<br/>UL LISTED ITE E350576</p> |
| <b>eWON COSY 131 WiFi</b>   | <b>eWON COSY 131 – 3G Penta</b>  | <b>eWON COSY 131 – 4G JP</b>   |

**EC6133m\_ccLL[suffix]**

| Position(s) | Description   | Acceptable values       |  |
|-------------|---|-------------------------|--|
| EC          | name of the family  | EC for eWON COSY        |  |
| 6           | number corresponding to the HW platform.                                  | 6                       | for "Cosy 131" platform                      |
| 1           | is communication options 1.   | 1                       | One Ethernet                                 |
| 3           | Is communication options 2.   | 3                       | Three Ethernet                               |
| 3           | field communication option.   | 3                       | USB  |
| m           | modem communication option.   | 0                       | No modem                                     |
|             |   | C                       | WiFi   |
|             |   | D                       | 3G+ Modem                                    |
|             |   | E                       | 4G Modem                                     |
| cc          | is one or more digits or letters that correspond to software options      | 00 = no software option |  |
| LL          | Defines the firmware language   | MA                      | UK + FR + DE + ES + IT                       |
| [suffix]    | can have an optional "/" character<br>Defines the compliances of the unit | S                       | compliance with the UL/IEC/EN 60950 standard |

**3.2. Mechanical dimensions**

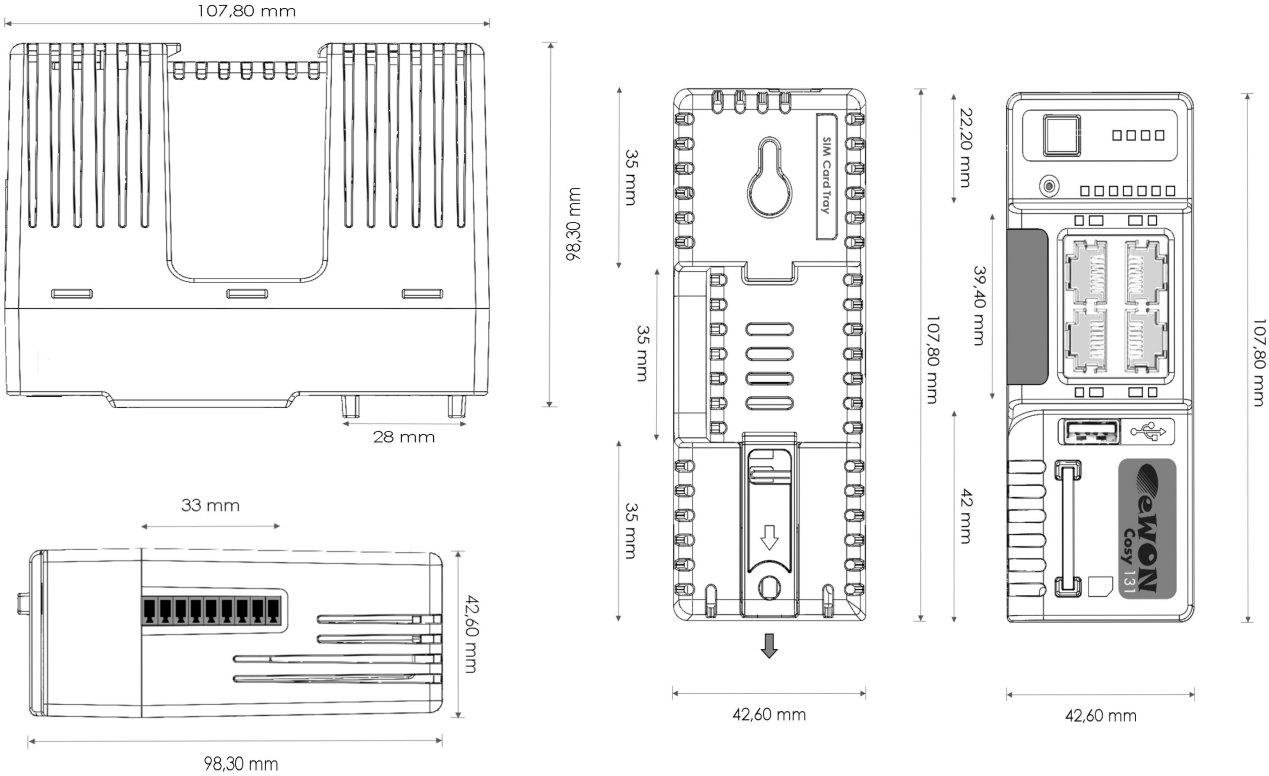

**3.3. Overall description**

**3.3.1. Front**

| # | Description   |
|---|---|
| 1 | Reset button  |
| 2 | Status LEDs   |
| 3 | LAN/WAN Ethernet ports and corresponding status LEDs<br>(Red: WAN / Green: LAN) |
| 4 | USB slot  |
| 5 | SD card slot  |

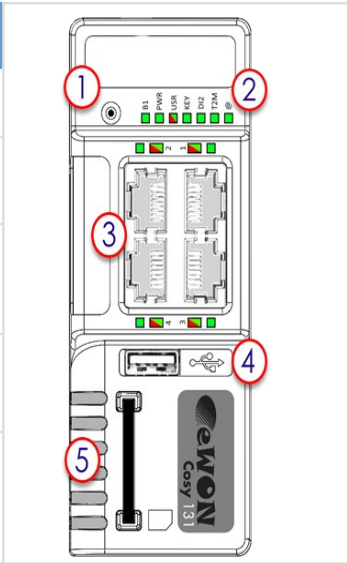

### 3.3.2. Upper side

#### Connector

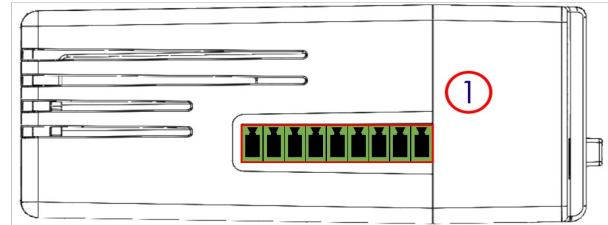
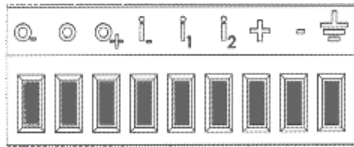

1

Main connector including power input terminal, 1DO and 2 DI

For more information about the connector see in [A.1. Main Connector](#)

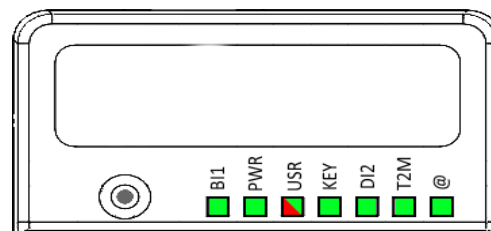

### 3.3.3. Status LED (COSY 131 – All version)



| Label      | Description   |
|------------|---|
| <b>BI1</b> | Button BI1 input<br>Green ON = Reset being pressed  |
| <b>PWR</b> | Power<br>Green ON = Power is present  |
| <b>USR</b> | User<br>Green ON+OFF slowly = Unit is OK<br>RED pattern = special attention required                              |
| <b>KEY</b> | Digital IN 1 – Green = ON: Signal on input 1 detected<br><a href="#">See. Digital Output &amp; Digital Inputs</a> |
| <b>DI2</b> | Digital IN 2 – Green = ON: Signal on input 2 detected<br><a href="#">See. Digital Output &amp; Digital Inputs</a> |
| <b>T2M</b> | Talk2M - Green ON = Talk2M VPN connection established<br><a href="#">See. Digital Output &amp; Digital Inputs</a> |
| <b>@</b>   | Internet<br>Green ON = Internet is configured on the eWON COSY  |

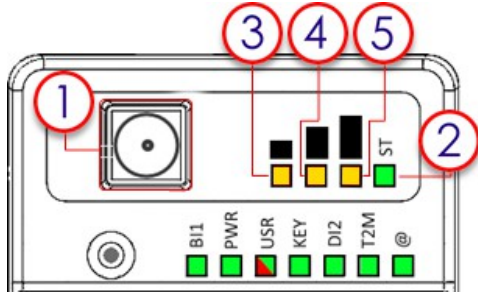

**3.3.3.1. WiFi Status LED (EC6133C)**

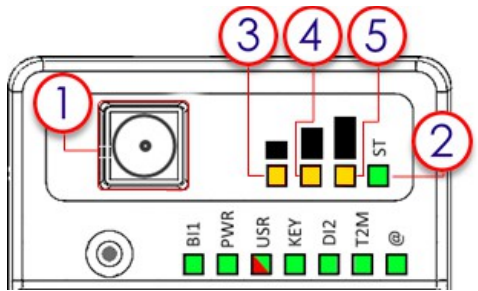

| # | Mark  | Description   |
|---|---|---|
| 1 | /   | SMA male connector for WIFI antenna                       |
| 2 | ST  | Modem status<br><b>Green</b> ON = WiFi connected          |
| 3 |    | Reception signal level<br><b>Orange</b> ON = Poor signal  |
| 4 |  | Reception signal level<br><b>Orange</b> ON = Signal is OK |
| 5 |  | Reception signal level<br><b>Orange</b> ON = Good signal  |

**3.3.3.2. Cellular Modem Status LED (EC6133D - EC6133E)**



| # | Mark  | Description   |
|---|---|---|
| 1 | /   | SMA female connector for GSM antenna                      |
| 2 | ST  | Modem status<br><b>Green</b> ON = Modem connected         |
| 3 |  | Reception signal level<br><b>Orange</b> ON = Poor signal  |
| 4 |  | Reception signal level<br><b>Orange</b> ON = Signal is OK |
| 5 |  | Reception signal level<br><b>Orange</b> ON = Good signal  |

### 3.4. Radio communication models

**- Warning -**

*This device is intended to be used in fixed or mobile applications only (not for portable applications). The antenna used for this transmitter has to be installed in a space providing a safe distance of at least 20 cm without encountering any person and must not be co-located or operating in conjunction with any other antenna or transmitter.*

#### 3.4.1. COSY 131 with internal WiFi modem

| Cosy 131 – Wifi                              |   |   |
|--|---|---|
| Item   | Value(s)  |   |
| <b>Protocols and Frequencies</b>             | IEEE802.11b/g/n, 2.4GHz - Channels: 1 to 11 (inclusive) |   |
| <b>Antenna Connector</b>                     | Type RP-SMA   |   |
| <b>Antenna</b><br>(included in the delivery) | Charact.  | Value(s)  |
|  | Impedance   | 50 Ohms   |
|  | Input Power   | > 17 dBm, IEEE 802.11b<br>> 15 dBm, IEEE 802.11g/n  |
|  | Tightening Torque                                       | 0.5 Nm. <i>In the absence of a torque wrench, a soft manual tightening is sufficient.</i> |

Device conformity has been tested with the reference antenna: Pulse W1030.

- The product complies with the R&TTE directive, the FCC, the IC and Japan regulations related to the Wifi communications.
- Absolute maximum antenna gain as per FCC's rules and regulations, 47CFR:
  - Part 15C : 2.14dBi
- Modifications cannot be made by the user if it influences the normal behavior of the device.
- *This product contains part identified as follows by national authorities:*
  - FCC ID: QOQWF111
  - IC ID: 5123A-BGTWF111
  - RRA ID: KCC-CRM-BGT-WF111
  - GITEKI (MIC) ID: 209-J00061



### 3.4.2. COSY 131 with internal 3G+ Penta-band modem

| Cosy 131 – Cellular 3G+                                 |  |   |
|---|--|---|
| Item  | Value(s)   |   |
| Protocols and Frequencies                               | GSM/GPRS/EDGE - 850, 900, 1800, 1900 MHz<br>UMTS/HSUPA - 800/850, 900,AWS 1700,1900,2100 Mhz |   |
| Class   | Penta-band GPRS/EDGE Class 33  |   |
| Antenna Connector                                       | Type SMA   |   |
| Antenna<br>(not included in the delivery <sup>1</sup> ) | Charact.   | Value(s)  |
|   | Impedance  | 50 Ohms   |
|   | VSWR   | <= 5:1 Absolute max. to avoid permanent damage<br><= 2:1 Limit to fulfill all regulatory requirements |
|   | Input Power  | > 33 dBm (2W) peak power in GSM<br>> 24 dBm average power in WCDMA                                    |
|   | Tightening Torque  | 0.5 Nm. <i>In the absence of a torque wrench, a soft manual tightening is sufficient.</i>             |

Device conformity has been tested with the reference antenna: Taoglas TG.09.0113

**- Note -**

As seen in [2.4.2.Mounting Recommendations](#) SIM Card Tray is at the rear of the COSY 131

- The product complies with the R&TTE directive, the FCC, the IC and Japan regulations related to the GSM modems.
- Absolute maximum antenna gain as per FCC's rules and regulations, 47 CFR :
  - Part 22H : 5.22dBi;
  - Part 27 : 3.31 dBi;
  - Part 24E : 6.45dBi.
- Modifications can't be made by the user if it influences the normal behavior of the device.
- *This product contains part identified as follows by national authorities:*
  - FFC ID: RI7HE910
  - IC ID: 5131A-HE910
  - GITEKI (MIC) ID: 005-100269

<sup>1</sup> 3G antenna has to be purchased separately. A 3G penta-band antenna is available from eWON with FAC90501\_0000 as reference



## Chapter 3

### Hardware description

- JATE ID: AD12-0318001

### 3.4.3. COSY 131 with internal 4G JP Quad-band modem

| Cosy 131 – Cellular 4G                                  |   |   |
|---|---|---|
| Item  | Value(s)  |   |
| Protocols and Frequencies                               | LTE : 850MHz (B19), 1500MHz (B21), 2100MHz (B1)<br>UMTS :800MHz (B6), 850MHz (B5, B19), 2100MHz (B1)<br>GSM, EDGE, GPRS: 850MHz, 900MHz, 1800MHz, 1900MHz |   |
| Antenna Connector                                       | Type SMA  |   |
| Antenna<br>(not included in the delivery <sup>2</sup> ) | Specs.  | Value(s)  |
|   | Impedance   | 50 Ohms   |
|   | VSWR  | < 3:1 Absolute maximum limit  |
|   | Input Power   | > 33 dBm (2W) peak power in GSM<br>> 24 dBm average power in WCDMA                        |
|   | Tightening Torque   | 0.5 Nm. <i>In the absence of a torque wrench, a soft manual tightening is sufficient.</i> |

*Device conformity assessment has been performed with the reference antenna: Taoglass G.30.B108111*

**- Note -**

*As seen in [2.4.2.Mounting Recommendations](#) SIM Card Tray is at the rear of the COSY 131*

- The product complies with the R&TTE directive, the FCC, the IC and Japan regulations related to the GSM modems.
- Absolute maximum antenna gain as per FCC's rules and regulations, 47 CFR :
  - – Part 22H : 5.22dBi;
  - – Part 27 : 3.31dBi;
  - – Part 24E : 6.45dBi.
- Modifications cannot be made by the user if it influences the normal behavior of the device.
- This product contains part identified as follows by Japanese authorities:
  - Radio Act: 005-100567
  - Telecom Act: AD13-0163005

<sup>2</sup> 4G antenna has to be purchased separately. A 4G Quad-band antenna is available from eWON with FAC90801\_0000 as reference



## 3.5. LAN Switch Specifications

### 3.5.1. Boot process

After powering ON or requesting a reboot on the eWON COSY 131, a few moment is required to get the LAN switch feature fully operational. (approximately 45 sec)

**- Note -**

*When an eWON router is configured to operate a certain way, it is part of the strategy, if no other method worked, to reboot itself. This is the ultimate decision the eWON takes in order to restore the requested communication channels and be consistent with requested configuration.*

### 3.5.2. LAN Switch configuration

At the very first boot or after a reset level 2, the Ethernet ports scheme will be configured as follows: PORT 1: **LAN**, PORT 2: **LAN**, PORT 3: **LAN**, PORT 4: **WAN**

The Ethernet ports functionality can be reconfigured except for the PORT 1 which always remain in **LAN** mode.

**- Note -**

*Ethernet Port 1 must be used for maintenance operation such as update or recovery process.*

## 4. COSY IP Address & Access to the Web Configuration

### 4.1. Factory Default IP settings

| Characteristics | Value(s)      |
|-----------------|---------------|
| LAN IP Address  | 10.0.0.53     |
| LAN Subnet Mask | 255.255.255.0 |
| Gateway         | 0.0.0.0       |

**- Note -**

*Since FW 10.0, the WAN IP address is set by default in DHCP mode*

### 4.2. Powering ON

Power on the unit and wait approximately 45 sec until the boot process is finished.

After a successful boot process the **USR** LED is flashing green slowly.

If the **USR** LED is flashing RED according to a given pattern, it indicates that the boot process was interrupted due to a problem. The most frequent problem is :

- a duplicate IP address was detected on the LAN Network  
**USR** LED flashing pattern is RED 1x short, 1x long

For the other LED patterns in case of error, please refer to the General Reference Guide RG-001.

### 4.3. Connecting to the eWON COSY LAN IP Address

You can easily establish your first communication with your eWON COSY by using our companion tool **eBuddy** which can be downloaded from

<https://ewon.biz/support/product/download-zone/all-software>

Connect one of the LAN-ports (by default, port N°1 is always a LAN port) of your COSY with your PC point-to-point or through a network where there is no risk that the eWON's default IP-address (10.0.0.53) would conflict with another connected device.

## 4.4. eWON COSY's Web Interface

Connect your PC to one of the LAN ports of the eWON COSY.

Open your Internet browser and access the eWON COSY Web server by typing the LAN IP address in the URL field (the default address is <http://10.0.0.53>).

Or use the eBuddy application to easily access to the eWON COSY

### - Note -

*Get-started with eBuddy and configure your eWON: [AUG-065: Reach an eWON with a suitable IP address using eBuddy](#)*

At very first boot of the eWON COSY (or after a level 2 reset), you will be asked to select the eWON language.

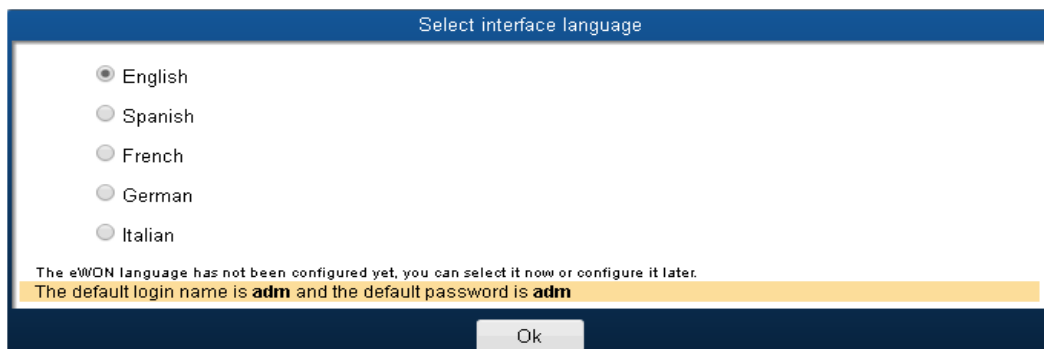

Before configuring your eWON COSY, an authentication is required.

The default login & password are both "adm".

### - Warning -

*For security reasons, changing the default password "adm" is absolutely required.*

Follow this wizard to configure your eWON Cosy and connect it to the Talk2M server.

On our website you can also find a Quick Start Guide which will help you configure your Cosy131: <https://ewon.biz/support/product/cosy-131-getting-started/getting-started>

## 5. Troubleshooting

### 5.1. Normal Boot Process

The normal boot process of the eWON COSY takes approximately 25 seconds to complete. During this process, all LEDs are first shortly ON (except B11) then only the **PWR** LED stays solid green.

As soon as the boot process is finished and the unit is ready to be used, the **USR** LED flashes GREEN slowly whereas others might be solid green (if you are connected to Internet, Talk2M, ...).

### 5.2. Resetting the eWON COSY 131

The reset button B1 is located on the front of the COSY unit (see in [3.3.1.Front](#)). The reset function of this button is active only if pressed while powering on.

The eWON COSY features two levels of reset:

#### 5.2.1. First Level Reset (user reset)

The first level reset is a selective one that erases the « **user files** » part and the system settings. This type of reset does not alter the communication parameters of the eWON COSY.

How to perform a first level reset?

- Power the unit OFF.
- While powering it ON, press & maintain the reset button.  
The LED labeled B11 turns ON.
- Keep the reset button pressed for approximately 30 seconds until the **USR** LED flashes RED 1x per second. If you don't release at that specific moment, you will perform a second level reset phase.  
The LED labeled B11 turns OFF.
- Wait approximately 30 secs until the reset process is completed.
- The eWON restarts automatically and the unit is ready to be used, the **USR** LED flashes GREEN slowly.

#### 5.2.2. Second Level Reset (factory reset)

This second level reset restores the eWON to its factory settings. This operation consists in 3 steps:

- Formats the entire non volatile memory, including all COM parameters and IP addresses
- Full hardware auto-test with result shown by the **USR** LED

- Return to ex-factory configuration (default config)

How to perform a second level reset?

- Power the unit OFF.
- While powering it ON, press & maintain the reset button. The LED labeled BI1 turns ON.
- Keep the reset button pressed for approximately 35 seconds until the **USR** LED remains RED steady.
- When this state is reached, release the button. The LED labeled BI1 turns OFF.
- It takes no longer than 2 seconds to complete.
- Check if the auto test is successful, the **USR** LED flashes RED with a pattern of 200ms ON and 1,5 sec OFF<sup>3</sup>. The eWON COSY **does NOT restart in normal mode** by itself and remains running in this diagnostic mode.
- You have to power the eWON COSY OFF and ON again to reboot the unit in normal mode. As described before, the eWON returns to its default COM parameters and factory IP addresses (such as LAN 10.0.0.53) after this level 2 reset is performed.

### 5.3. Reset Impact Matrix

|  | Erased or Reset  | Preserved                           |
|--|--|-------------------------------------|
| Impact<br>Reset Level 1<br>(user reset)    |  | LAN IP address + mask               |
|  | adm password   | Internet access                     |
|  |  | Language settings                   |
|  | eWON Identification  | Modem/ Wifi settings                |
|  | User Web site  | Talk2M configuration                |
|  |  | Proxy configuration                 |
|  |  | LAN Switch configuration            |
|  |  | Gateway (USB, NAT 1:1) <sup>4</sup> |
| Impact<br>Reset Level 2<br>(factory reset) | eWON will be reset to factory settings, all parameters will be lost. |                                     |

<sup>3</sup> Any other pattern reflects a problem. The pattern will start with 200ms ON (opening of the pattern) followed by OFF and a certain number of times of a 1 sec ON allowing to identify the nature of the detected problem. If you face an error pattern on the **USR** LED, please check on the troubleshooting page: [ewon.biz/support](http://ewon.biz/support)

<sup>4</sup> Configuration remains even if the Wizards on eWON web interface indicate otherwise.



## Appendix A - Connector Pinout & Related Specifications

### A.1 - Main Connector

As shown in the picture, the female mating connector is labeled with the appropriate symbols.

| Characteristic            | Value   |
|---------------------------|---|
| Connector type            | MINICONNEC MC model<br>Type MC 1,5/9-ST-3,5<br>Pitch = 3.50 mm<br>9-pin female            |
| Connector pinout          |        |
| Maximal tightening torque | 0.25Nm. <i>In the absence of a torque wrench, a soft manual tightening is sufficient.</i> |

| PIN | ICON  | ID               | Description   |
|-----|---|------------------|---|
| 1   | O.  | DO_COM           | Output signal (0V ground) connected to the emitter of the MOSFET transistor |
| 2   | O   | DO               | Output signal connected to the drain of the MOSFET transistor               |
| 3   | O+  | DO_VDC           | Common of the external predrive power supply (between +12 et +24 VDC)       |
| 4   | i.  | DI_COM           | Ground of the input (isolated)  |
| 5   | i <sub>1</sub>  | DI1              | Input signal 1  |
| 6   | i <sub>2</sub>  | DI2              | Input signal 2  |
| 7   | +   | Power in VDD +   | between +12 et +24 VDC  |
| 8   | -   | Power in GND -   | 0V  |
| 9   |  | Functional Earth |   |

## A.2 - Specification of the External Power Supply

The eWON COSY must be powered by a safety Low Power Supply (LPS) in accordance with clause 2.5 of UL/IEC 60950-1 Ed2. Standard, 12-24Vdc, 30W min. Certified for 60°C and for altitudes up to 2000m. The safety LPS power supply is not part of the delivery.

### Suggested power supply:

SIEMENS SITOP logo power 24V 2.5A 60W - Siemens order ref: 6EP1332-1SH43.

Equivalents are available on the market.

| Power Supply                |                                      |
|-----------------------------|--------------------------------------|
| Characteristic              | Value                                |
| Power supply voltage        | external 12-24 VDC +/- 19%           |
| Max COSY input power        | 30W max.                             |
| Internal voltage protection | max 30V                              |
| Input protection            | protected against polarity inversion |

## A.3 - Digital Output & Digital Inputs

| Characteristic                      | Value                                   |
|-------------------------------------|---|
| Type of digital output <sup>5</sup> | Open drain MOSFET                       |
| Max. current (ext,source)           | 200 mA                                  |
| Isolation (both DI & DO)            | 1,5 kV                                  |
| DI voltage range                    | 0 to 24 VDC                             |
| DI protection                       | 33 VDC Max                              |
| DI OFF state input voltage range    | 0 to 5 VDC                              |
| DI ON state input voltage range     | 10 to 30 VDC                            |
| DI ON state current range           | From 3,8 mA @ 12 VDC to 8,2 mA @ 24 VDC |

<sup>5</sup> During the starting boot process, the DO will be switched ON for a short time (2 sec)



## Appendix A - Connector Pinout & Related Specifications

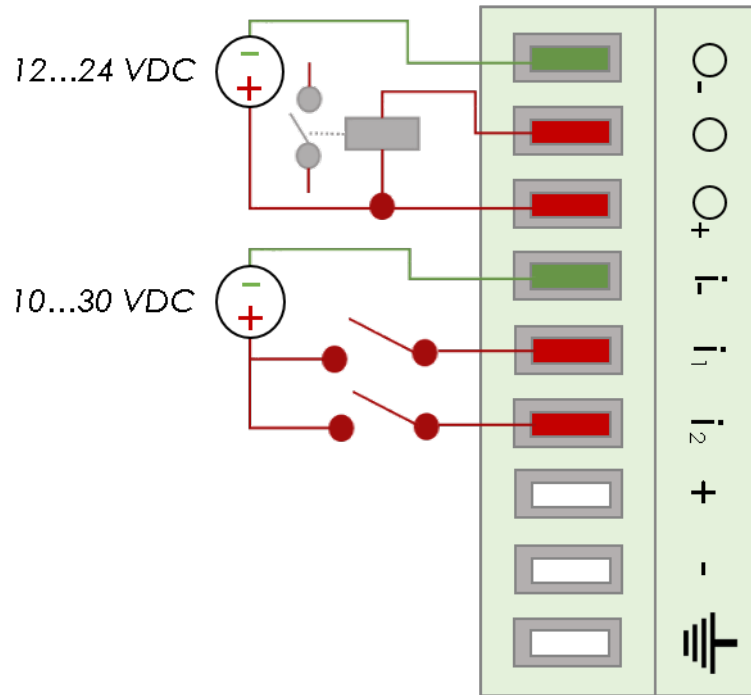

The digital output is activated by an open drain MOSFET transistor driven by an optocoupler. The maximum current flow inside this transistor has a value above the one specified in the eWON, in order to cope with the switching power losses.

The transistor used is in an open drain type with predrive. This means the relay power supply has to be supplied from an external source to the predrive electronics.

The diagram below shows the external wiring needed for proper operation of the digital output. A relay has been chosen for this sample application but any load within the specifications can be used instead.

**- Note -**

*This is a sink only output to ground (the transistor acts as a switch ground).*

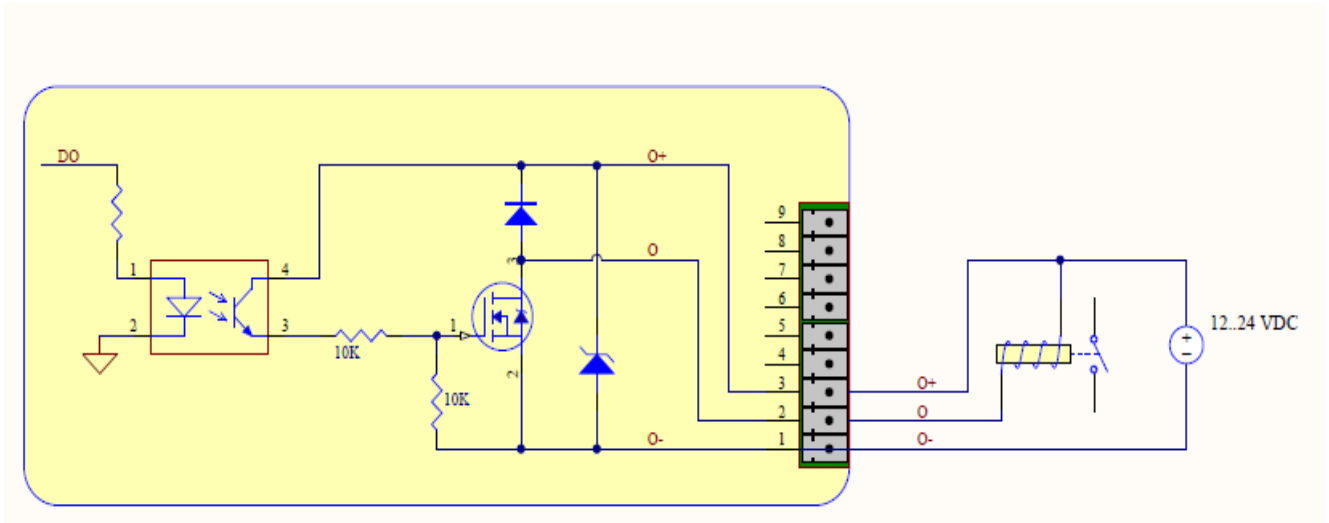

Possible features :

Wiring the Digital Output & Inputs can be use to externalize some features (as connectivity condition)

| LED | Connector | Description   |
|-----|-----------|---|
| KEY | DI1       | to authorize or prevent the Internet connection.  |
|     |           | to authorize or prevent the VPN connection.   |
| DI2 | DI2       | Not implemented.  |
| T2M | DO        | Can be wired to an external device to propagate the Talk2M status. If the VPN connection is active, the DO is set to 1. |

The configuration of this condition has to be done during the Internet Wizard where you define if the digital input is used or not and for which purpose.

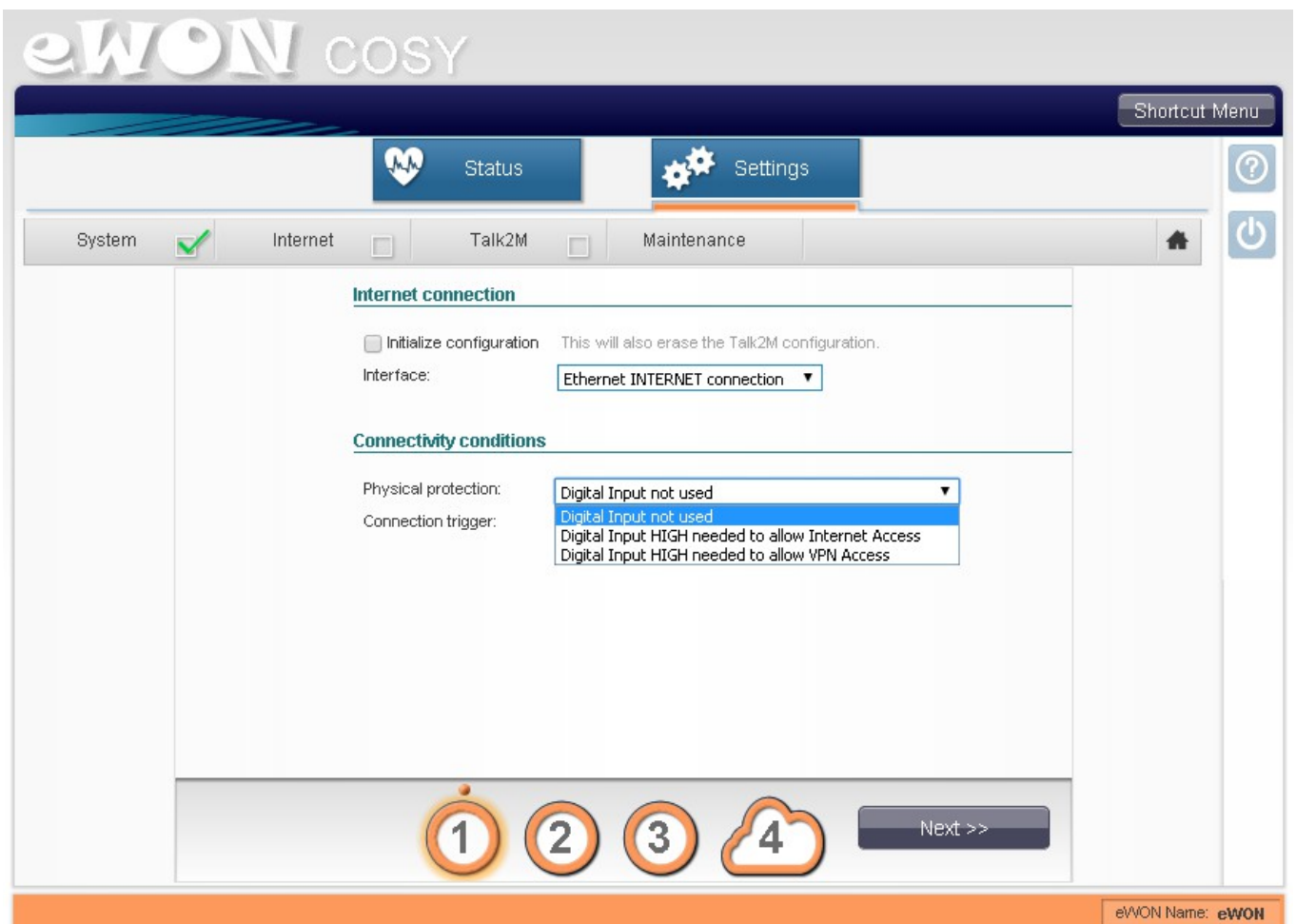

The screenshot shows the eWON COSY web interface. At the top, there is a navigation bar with 'Status' and 'Settings' tabs. Below this, there are status indicators for 'System' (checked), 'Internet' (unchecked), 'Talk2M' (unchecked), and 'Maintenance'. The main content area is titled 'Internet connection' and includes the following settings:

- Initialize configuration: This will also erase the Talk2M configuration.
- Interface: Ethernet INTERNET connection
- Connectivity conditions:
  - Physical protection: Digital Input not used
  - Connection trigger: Digital Input not used, Digital Input HIGH needed to allow Internet Access, Digital Input HIGH needed to allow VPN Access

At the bottom of the interface, there is a progress indicator with four numbered steps (1, 2, 3, 4) and a 'Next >>' button. The footer shows 'eWON Name: eWON'.

### A.4 - Supported Wireless WiFi Frequencies

## Appendix A - Connector Pinout & Related Specifications

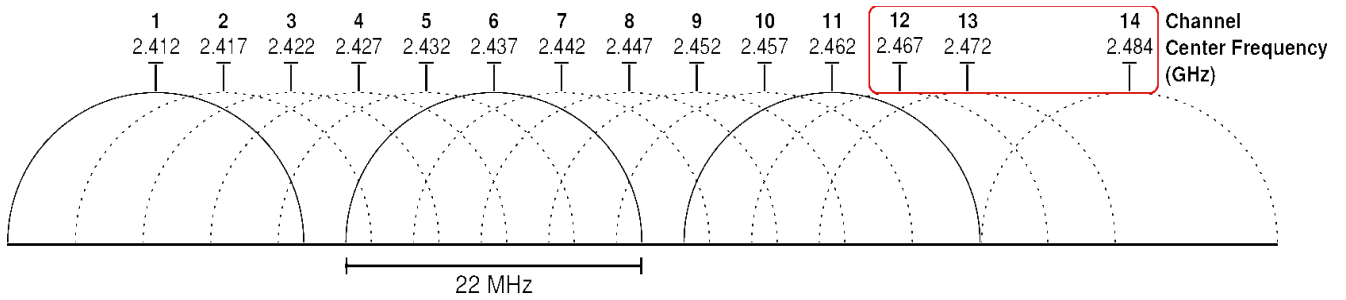

- **Channels 12, 13 & 14 are not supported**

Supported channels frequencies are between: Channel 1 - 2,412 Ghz and 11 - 2,462 Ghz

## Revision

### Revision History

| Revision | Date       | Description  |
|----------|------------|--|
| 1.0      | 22/01/2015 | Original Document  |
| 1.1      | 04/02/2015 | Pictures modifications   |
| 1.2      | 27/04/2015 | WiFi & DI/DO Updates ( <a href="#">3.4.1 A.3</a> , <a href="#">A.4</a> ) |
| 1.3      | 30/06/2015 | Added Cabling rules ( <a href="#">#2.4.3.Cabling rules</a> )             |
| 1.4      | 17/11/2015 | Added section 3.5: LAN Switch Specifications                             |
| 1.5      | 11/01/2016 | Modified DO Diagram  |
| 1.6      | 14/06/2016 | Added COSY EC6133E + Digital I/O update                                  |
| 1.7      | 27/07/2016 | Update of Legal References   |

#### Document build number: 19

#### Note concerning the warranty and the rights of ownership:

The information contained in this document is subject to modification without notice. Check <http://support.ewon.biz> for the latest documents releases.

The vendor and the authors of this manual are not liable for the errors it may contain, nor for their eventual consequences.

No liability or warranty, explicit or implicit, is made concerning the quality, the accuracy and the correctness of the information contained in this document. In no case the manufacturer's responsibility could be called for direct, indirect, accidental or other damage occurring from any defect of the product or errors coming from this document.

The product names are mentioned in this manual for information purposes only. The trade marks and the product names or marks contained in this document are the property of their respective owners.

This document contains materials protected by the International Copyright Laws. All reproduction rights are reserved. No part of this handbook can be reproduced, transmitted or copied in any way without written consent from the manufacturer and/or the authors of this handbook.

eWON sa